

# Jason Industrial Inc.®

A MEGADYNE GROUP CO.

## POWER TRANSMISSION V-BELTS

Select Multi-Plus® A & B Belts and  
Discontinue Your 4L & 5L  
Inventory!

Dual Part Number System is more  
than just labeling.

FHP & Classical have the same top dimension. Heavy Duty  
Classical is deeper, allowing more belt/pulley contact.

- up to **double** the horsepower rating
- reduces sheave wear
- reduce inventory carrying only one style
- made to perform
- priced to compete

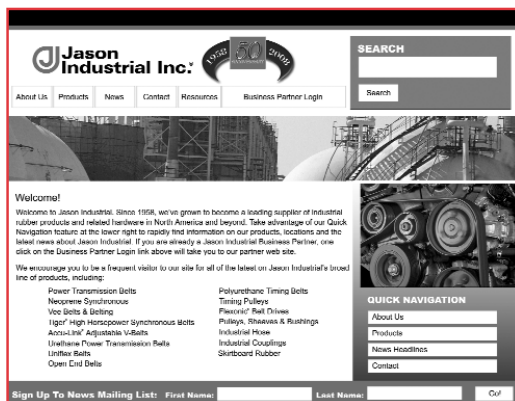
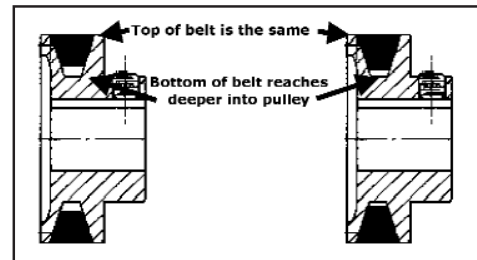

Now access to Jason Industrial is  
available to you 24 hours a day,  
7 days a week!

Introducing Jason's new online  
Business-to-Business Module!

[www.jasonindustrial.com](http://www.jasonindustrial.com)

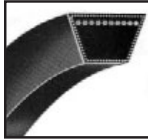

**F.H.P. V-BELTS**  
**3L SECTION 3/8" Top x 7/32" Thick x 40° Angle**

Belt Number	Outside Length	Belt Number	Outside Length	Belt Number	Outside Length	Belt Number	Outside Length
3L 130	13"	3L 290	29"	3L 450	45"	3L 610	61"
3L 140	14"	3L 300	30"	3L 460	46"	3L 620	62"
3L 150	15"	3L 310	31"	3L 470	47"	3L 630	63"
3L 160	16"	3L 315	31.5"	3L 475	47.5"	3L 640	64"
3L 170	17"	3L 320	32"	3L 480	48"	3L 650	65"
3L 180	18"	3L 330	33"	3L 490	49"	3L 660	66"
3L 190	19"	3L 340	34"	3L 500	50"	3L 670	67"
3L 200	20"	3L 350	35"	3L 510	51"	3L 680	68"
3L 210	21"	3L 360	36"	3L 520	52"	3L 690	69"
3L 220	22"	3L 370	37"	3L 530	53"	3L 700	70"
3L 230	23"	3L 380	38"	3L 540	54"	3L 710	71"
3L 240	24"	3L 390	39"	3L 550	55"	3L 720	72"
3L 250	25"	3L 400	40"	3L 560	56"	3L 730	73"
3L 260	26"	3L 410	41"	3L 570	57"	3L 740	74"
3L 270	27"	3L 420	42"	3L 580	58"	3L 750	75"
3L 280	28"	3L 430	43"	3L 590	59"	3L 760	76"
3L 285	28.5"	3L 440	44"	3L 600	60"		

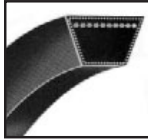

**\*MULTI-PLUS® V-BELTS**  
**"A" SECTION 1/2" Top x 11/32" Thick x 40° Angle**

A 15 (4L 160)	16"	A 46 (4L 480)	48"	A 78 (4L 800)	80"	A 110	112"
A 16 (4L 170)	17"	A 47 (4L 490)	49"	A 79 (4L 810)	81"	A 111	113"
A 18 (4L 180)	18"	A 48 (4L 500)	50"	A 80 (4L 820)	82"	A 112	114"
A 17 (4L 190)	19"	A 49 (4L 510)	51"	A 81 (4L 830)	83"	A 113	115"
A 18 (4L 200)	20"	A 50 (4L 520)	52"	A 82 (4L 840)	84"	A 114	116"
A 19 (4L 210)	21"	A 51 (4L 530)	53"	A 83 (4L 850)	85"	A 115	117"
A 20 (4L 220)	22"	A 52 (4L 540)	54"	A 84 (4L 860)	86"	A 116	118"
A 21 (4L 230)	23"	A 53 (4L 550)	55"	A 85 (4L 870)	87"	A 118	120"
A 22 (4L 240)	24"	A 54 (4L 560)	56"	A 86 (4L 880)	88"	A 119	121"
A 23 (4L 250)	25"	A 55 (4L 570)	57"	A 87 (4L 890)	89"	A 120	122"
A 24 (4L 260)	26"	A 56 (4L 580)	58"	A 88 (4L 900)	90"	A 124	126"
A 25 (4L 270)	27"	A 57 (4L 590)	59"	A 89 (4L 910)	91"	A 128	130"
A 26 (4L 280)	28"	A 58 (4L 600)	60"	A 90 (4L 920)	92"	A 130	132"
A 27 (4L 290)	29"	A 59 (4L 610)	61"	A 91 (4L 930)	93"	A 133	135"
A 28 (4L 300)	30"	A 60 (4L 620)	62"	A 92 (4L 940)	94"	A 134	136"
A 29 (4L 310)	31"	A 61 (4L 630)	63"	A 93 (4L 950)	95"	A 135	137"
A 30 (4L 320)	32"	A 62 (4L 640)	64"	A 94 (4L 960)	96"	A 136	138"
A 31 (4L 330)	33"	A 63 (4L 650)	65"	A 95 (4L 970)	97"	A 137	139"
A 32 (4L 340)	34"	A 64 (4L 660)	66"	A 96 (4L 980)	98"	A 140	142"
A 33 (4L 350)	35"	A 65 (4L 670)	67"	A 97 (4L 990)	99"	A 144	146"
A 34 (4L 360)	36"	A 66 (4L 680)	68"	A 98 (4L 1000)	100"	A 157	159"
A 35 (4L 370)	37"	A 67 (4L 690)	69"	A 99	101"	A 158	160"
A 36 (4L 380)	38"	A 68 (4L 700)	70"	A 100	102"	A 162	164"
A 37 (4L 390)	39"	A 69 (4L 710)	71"	A 101	103"	A 173	175"
A 38 (4L 400)	40"	A 70 (4L 720)	72"	A 102	104"	A 180	182"
A 39 (4L 410)	41"	A 71 (4L 730)	73"	A 103	105"	A 196	198"
A 40 (4L 420)	42"	A 72 (4L 740)	74"	A 104	106"	A 197	199"
A 41 (4L 430)	43"	A 73 (4L 750)	75"	A 105	107"	A 210	212"
A 42 (4L 440)	44"	A 74 (4L 760)	76"	A 106	108"	A 221	223"
A 43 (4L 450)	45"	A 75 (4L 770)	77"	A 107	109"	A 256	258"
A 44 (4L 460)	46"	A 76 (4L 780)	78"	A 108	110"	A 258	260"
A 45 (4L 470)	47"	A 77 (4L 790)	79"	A 109	111"		

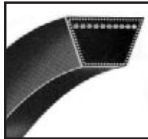

**\*MULTI-PLUS® V-BELTS**  
**"B" SECTION 21/32" Top x 7/16" Thick x 40° Angle**

5L 220	22"	B 29 (5L 320)	32"	B 40 (5L 430)	43"	B 51 (5L 540)	54"
5L 230	23"	B 30 (5L 330)	33"	B 41 (5L 440)	44"	B 52 (5L 550)	55"
B 20	23"	B 31 (5L 340)	34"	B 42 (5L 450)	45"	B 53 (5L 560)	56"
B 21 (5L 240)	24"	B 32 (5L 350)	35"	B 43 (5L 460)	46"	B 54 (5L 570)	57"
B 22 (5L 250)	25"	B 33 (5L 360)	36"	B 44 (5L 470)	47"	B 55 (5L 580)	58"
B 23 (5L 260)	26"	B 34 (5L 370)	37"	B 45 (5L 480)	48"	B 56 (5L 590)	59"
B 24 (5L 270)	27"	B 35 (5L 380)	38"	B 46 (5L 490)	49"	B 57 (5L 600)	60"
B 25 (5L 280)	28"	B 36 (5L 390)	39"	B 47 (5L 500)	50"	B 58 (5L 610)	61"
B 26 (5L 290)	29"	B 37 (5L 400)	40"	B 48 (5L 510)	51"	B 59 (5L 620)	62"
B 27 (5L 300)	30"	B 38 (5L 410)	41"	B 49 (5L 520)	52"	B 60 (5L 630)	63"
B 28 (5L 310)	31"	B 39 (5L 420)	42"	B 50 (5L 530)	53"	B 61 (5L 640)	64"



**\*MULTI-PLUS® V-BELTS**  
**"B" SECTION 21/32" Top x 7/16" Thick x 40° Angle**

Belt Number	Outside Length	Belt Number	Outside Length	Belt Number	Outside Length	Belt Number	Outside Length
B 62 (5L 650)	65"	B 96 (5L 990)	99"	B 134	137"	B 205	208"
B 63 (5L 660)	66"	B 97 (5L 1000)	100"	B 135	138"	B 210	213"
B 64 (5L 670)	67"	B 98 (5L 1010)	101"	B 136	139"	B 215	216"
B 65 (5L 680)	68"	B 99 (5L 1020)	102"	B 138	141"	B 221	222"
B 66 (5L 690)	69"	B 100	103"	B 140	143"	B 223	224"
B 67 (5L 700)	70"	B 101	104"	B 141	144"	B 224	225"
B 68 (5L 710)	71"	B 102	105"	B 142	145"	B 225	226"
B 69 (5L 720)	72"	B 103	106"	B 144	147"	B 228	229"
B 70 (5L 730)	73"	B 104	107"	B 147	150"	B 229	230"
B 71 (5L 740)	74"	B 105	108"	B 148	151"	B 234	235"
B 72 (5L 750)	75"	B 106	109"	B 150	153"	B 237	238"
B 73 (5L 760)	76"	B 107	110"	B 152	155"	B 240	241"
B 74 (5L 770)	77"	B 108	111"	B 153	156"	B 248	249"
B 75 (5L 780)	78"	B 109	112"	B 154	157"	B 253	254"
B 76 (5L 790)	79"	B 110	113"	B 156	159"	B 255	256"
B 77 (5L 800)	80"	B 111	114"	B 157	160"	B 259	260"
B 78 (5L 810)	81"	B 112	115"	B 158	161"	B 265	266"
B 79 (5L 820)	82"	B 113	116"	B 162	165"	B 270	271"
B 80 (5L 830)	83"	B 114	117"	B 163	166"	B 276	277"
B 81 (5L 840)	84"	B 115	118"	B 165	168"	B 285	286"
B 82 (5L 850)	85"	B 116	119"	B 168	171"	B 292	293"
B 83 (5L 860)	86"	B 118	121"	B 170	173"	B 293	294"
B 84 (5L 870)	87"	B 120	123"	B 173	176"	B 300	301"
B 85 (5L 880)	88"	B 122	125"	B 175	178"	B 315	316"
B 86 (5L 890)	89"	B 123	126"	B 177	180"	B 330	331"
B 87 (5L 900)	90"	B 124	127"	B 180	183"	B 333	334"
B 88 (5L 910)	91"	B 125	128"	B 182	185"	B 345	346"
B 89 (5L 920)	92"	B 126	129"	B 184	187"	B 360	361"
B 90 (5L 930)	93"	B 127	130"	B 188	191"	B 394	395"
B 91 (5L 940)	94"	B 128	131"	B 190	193"	B 433	434"
B 92 (5L 950)	95"	B 130	133"	B 192	195"	B 472	473"
B 93 (5L 960)	96"	B 131	134"	B 195	198"		
B 94 (5L 970)	97"	B 132	135"	B 197	200"		
B 95 (5L 980)	98"	B 133	136"	B 204	207"		

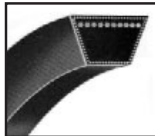

**"C" SECTION 7/8" Top 17/32" Thick x 40° Angle**

C 41	45"	C 81	85"	C 130	134"	C 200	204"
C 43	47"	C 83	87"	C 132	136"	C 202	206"
C 45	49"	C 85	89"	C 134	138"	C 204	208"
C 46	50"	C 86	90"	C 136	140"	C 207	211"
C 47	51"	C 87	91"	C 138	142"	C 208	212"
C 48	52"	C 88	92"	C 140	144"	C 210	214"
C 50	54"	C 90	94"	C 141	145"	C 220	222"
C 51	55"	C 92	96"	C 142	146"	C 225	227"
C 52	56"	C 93	97"	C 143	147"	C 228	230"
C 53	57"	C 94	98"	C 144	148"	C 238	240"
C 54	58"	C 96	100"	C 148	152"	C 240	242"
C 55	59"	C 97	101"	C 150	154"	C 245	247"
C 56	60"	C 98	102"	C 152	156"	C 246	248"
C 57	61"	C 99	103"	C 153	157"	C 248	250"
C 58	62"	C 100	104"	C 154	158"	C 255	257"
C 59	63"	C 101	105"	C 155	159"	C 270	272"
C 60	64"	C 102	106"	C 156	160"	C 276	278"
C 62	66"	C 103	107"	C 158	162"	C 280	282"
C 63	67"	C 104	108"	C 159	163"	C 285	287"
C 64	68"	C 105	109"	C 160	164"	C 297	299"
C 65	69"	C 106	110"	C 162	166"	C 300	302"
C 66	70"	C 108	112"	C 166	170"	C 303	305"
C 67	71"	C 109	113"	C 168	172"	C 314	316"
C 68	72"	C 110	114"	C 172	176"	C 315	317"
C 69	73"	C 112	116"	C 173	177"	C 330	332"
C 70	74"	C 115	119"	C 175	179"	C 345	347"
C 72	76"	C 116	120"	C 177	181"	C 360	362"
C 73	77"	C 118	122"	C 180	184"	C 390	392"
C 75	79"	C 120	124"	C 185	189"	C 420	422"
C 78	82"	C 124	128"	C 188	192"	C 480	482"
C 79	83"	C 126	130"	C 190	194"		
C 80	84"	C 128	132"	C 195	199"		

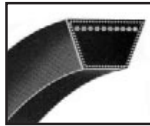

**"D" SECTION 1-1/4" Top 3/4" Thick x 40° Angle**

Belt Number	Outside Length	Belt Number	Outside Length	Belt Number	Outside Length	Belt Number	Outside Length
D90	95"	D171	176"	D270	273"	D420	423"
D105	110"	D173	178"	D285	288"	D441	444"
D115	120"	D180	185"	D300	303"	D450	453"
D120	125"	D195	200"	D315	318"	D480	483"
D128	133"	D205	210"	D330	333"	D540	543"
D132	137"	D210	215"	D345	348"	D600	603"
D136	141"	D225	228"	D355	358"	D660	663"
D144	149"	D240	243"	D360	363"		
D158	163"	D248	251"	D390	393"		
D162	167"	D255	258"	D394	397"		



**MOLDED COGGED V-BELTS  
"AX" SECTION 1/2" Top x 11/32" Thick x 40° Angle**

AX 22	24"	AX 40	42"	AX 58	60"	AX 78	80"
AX 23	25"	AX 41	43"	AX 59	61"	AX 80	82"
AX 24	26"	AX 42	44"	AX 60	62"	AX 84	86"
AX 25	27"	AX 43	45"	AX 61	63"	AX 85	87"
AX 26	28"	AX 44	46"	AX 62	64"	AX 86	88"
AX 27	29"	AX 45	47"	AX 63	65"	AX 90	92"
AX 28	30"	AX 46	48"	AX 64	66"	AX 92	94"
AX 29	31"	AX 47	49"	AX 65	67"	AX 96	98"
AX 30	32"	AX 48	50"	AX 66	68"	AX 105	107"
AX 31	33"	AX 49	51"	AX 67	69"	AX 108	110"
AX 32	34"	AX 50	52"	AX 68	70"	AX 110	112"
AX 33	35"	AX 51	53"	AX 69	71"	AX 112	114"
AX 34	36"	AX 52	54"	AX 70	72"	AX 120	122"
AX 35	37"	AX 53	55"	AX 71	73"	AX 128	130"
AX 36	38"	AX 54	56"	AX 72	74"	AX 136	138"
AX 37	39"	AX 55	57"	AX 73	75"		
AX 38	40"	AX 56	58"	AX 75	77"		
AX 39	41"	AX 57	59"	AX 76	78"		



**MOLDED COGGED V-BELTS  
"BX" SECTION 21/32" Top x 7/16" Thick x 40° Angle**

BX 30	33"	BX 59	62"	BX 65	68"	BX 95	98"
BX 31	34"	BX 60	63"	BX 66	69"	BX 96	99"
BX 32	35"	BX 61	64"	BX 67	70"	BX 97	100"
BX 33	36"	BX 62	65"	BX 68	71"	BX 98	101"
BX 34	37"	BX 63	66"	BX 69	72"	BX 99	102"
BX 35	38"	BX 64	67"	BX 70	73"	BX 100	103"
BX 36	39"	BX 65	68"	BX 71	74"	BX 103	106"
BX 37	40"	BX 66	69"	BX 72	75"	BX 105	108"
BX 38	41"	BX 67	70"	BX 73	76"	BX 108	111"
BX 39	42"	BX 68	71"	BX 74	77"	BX 112	115"
BX 40	43"	BX 69	72"	BX 75	78"	BX 113	116"
BX 41	44"	BX 70	73"	BX 76	79"	BX 115	118"
BX 42	45"	BX 71	74"	BX 77	80"	BX 116	119"
BX 43	46"	BX 72	75"	BX 78	81"	BX 120	123"
BX 44	47"	BX 73	76"	BX 79	82"	BX 124	127"
BX 45	48"	BX 74	77"	BX 80	83"	BX 128	131"
BX 46	49"	BX 75	78"	BX 81	84"	BX 133	135"
BX 47	50"	BX 76	79"	BX 82	85"	BX 136	139"
BX 48	51"	BX 77	80"	BX 83	86"	BX 144	147"
BX 49	52"	BX 54	57"	BX 84	87"	BX 150	153"
BX 50	53"	BX 55	58"	BX 85	88"	BX 158	161"
BX 51	54"	BX 56	59"	BX 86	89"	BX 162	163"
BX 52	55"	BX 57	60"	BX 87	90"	BX 173	176"
BX 53	56"	BX 58	61"	BX 88	91"	BX 180	183"
BX 54	57"	BX 59	62"	BX 89	92"	BX 195	198"
BX 55	58"	BX 60	63"	BX 90	93"	BX 210	213"
BX 56	59"	BX 61	64"	BX 91	94"	BX 225	226.5"
BX 57	60"	BX 62	65"	BX 92	95"	BX 240	241.5"
BX 58	61"	BX 63	66"	BX 93	96"	BX 255	256.5"
		BX 64	67"	BX 94	97"	BX 270	271.5"

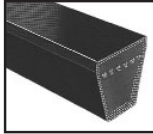

**DEEP WEDGE V-BELTS**  
**"3V" SECTION 3/8" Top x 5/16" Thick x 38° Angle**

Belt Number	Outside Length	Belt Number	Outside Length	Belt Number	Outside Length	Belt Number	Outside Length
<b>3V250</b>	25"	<b>3V425</b>	42.5"	<b>3V670</b>	67"	<b>3V1000</b>	100"
<b>3V265</b>	26"	<b>3V450</b>	45"	<b>3V710</b>	71"	<b>3V1060</b>	106"
<b>3V280</b>	28"	<b>3V475</b>	47.5"	<b>3V730</b>	73"	<b>3V1120</b>	112"
<b>3V300</b>	30"	<b>3V500</b>	50"	<b>3V750</b>	75"	<b>3V1180</b>	118"
<b>3V315</b>	31.5"	<b>3V530</b>	53"	<b>3V800</b>	80"	<b>3V1250</b>	125"
<b>3V335</b>	33.5"	<b>3V560</b>	56"	<b>3V830</b>	83"	<b>3V1320</b>	132"
<b>3V355</b>	35.5"	<b>3V600</b>	60"	<b>3V850</b>	85"	<b>3V1400</b>	140"
<b>3V375</b>	37.5"	<b>3V630</b>	63"	<b>3V900</b>	90"		
<b>3V400</b>	40"	<b>3V650</b>	65"	<b>3V950</b>	95"		

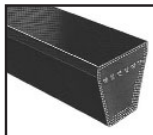

**DEEP WEDGE V-BELTS**  
**"5V" SECTION 5/8" Top x 17/32" Thick x 38° Angle**

<b>5V500</b>	50"	<b>5V850</b>	85"	<b>5V1400</b>	140"	<b>5V2240</b>	224"
<b>5V530</b>	53"	<b>5V900</b>	90"	<b>5V1500</b>	150"	<b>5V2360</b>	236"
<b>5V560</b>	56"	<b>5V950</b>	95"	<b>5V1600</b>	160"	<b>5V2500</b>	250"
<b>5V600</b>	60"	<b>5V1000</b>	100"	<b>5V1630</b>	163"	<b>5V2650</b>	265"
<b>5V630</b>	63"	<b>5V1060</b>	106"	<b>5V1700</b>	170"	<b>5V2800</b>	280"
<b>5V670</b>	67"	<b>5V1120</b>	112"	<b>5V1800</b>	180"	<b>5V3000</b>	300"
<b>5V710</b>	71"	<b>5V1180</b>	118"	<b>5V1900</b>	190"	<b>3V3150</b>	315"
<b>5V750</b>	75"	<b>5V1250</b>	125"	<b>5V2000</b>	200"	<b>3V3350</b>	335"
<b>5V800</b>	80"	<b>5V1320</b>	132"	<b>5V2120</b>	212"	<b>3V3550</b>	355"



**WEDGE COGGED V-BELTS**  
**"3VX" SECTION 3/8" Top x 5/15" Thick x 38° Angle**

<b>3VX 250</b>	25"	<b>3VX 390</b>	39"	<b>3VX 630</b>	63"	<b>3VX 1060</b>	106"
<b>3VX 265</b>	26.5"	<b>3VX 400</b>	40"	<b>3VX 670</b>	67"	<b>3VX 1120</b>	112"
<b>3VX 280</b>	28"	<b>3VX 425</b>	42.5"	<b>3VX 710</b>	71"	<b>3VX 1180</b>	118"
<b>3VX 290</b>	29"	<b>3VX 450</b>	45"	<b>3VX 750</b>	75"	<b>3VX 1250</b>	125"
<b>3VX 300</b>	30"	<b>3VX 475</b>	47.5"	<b>3VX 800</b>	80"	<b>3VX 1320</b>	132"
<b>3VX 315</b>	31.5"	<b>3VX 500</b>	50"	<b>3VX 850</b>	85"	<b>3VX 1400</b>	140"
<b>3VX 335</b>	33.5"	<b>3VX 530</b>	53"	<b>3VX 900</b>	90"		
<b>3VX 355</b>	35.5"	<b>3VX 560</b>	56"	<b>3VX 950</b>	95"		
<b>3VX 375</b>	37.5"	<b>3VX 600</b>	60"	<b>3VX 1000</b>	100"		

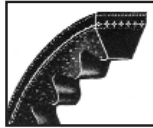

**WEDGE COGGED V-BELTS**  
**"5VX" SECTION 5/8" Top x 17/32" Thick x 38° Angle**

<b>5VX 450</b>	45"	<b>5VX 610</b>	61"	<b>5VX 830</b>	83"	<b>5VX 1120</b>	112"
<b>5VX 470</b>	47"	<b>5VX 630</b>	63"	<b>5VX 840</b>	84"	<b>5VX 1150</b>	115"
<b>5VX 490</b>	49"	<b>5VX 650</b>	65"	<b>5VX 850</b>	85"	<b>5VX 1180</b>	118"
<b>5VX 500</b>	50"	<b>5VX 670</b>	67"	<b>5VX 860</b>	86"	<b>5VX 1230</b>	123"
<b>5VX 510</b>	51"	<b>5VX 680</b>	68"	<b>5VX 880</b>	88"	<b>5VX 1250</b>	125"
<b>5VX 530</b>	53"	<b>5VX 690</b>	69"	<b>5VX 900</b>	90"	<b>5VX 1320</b>	132"
<b>5VX 540</b>	54"	<b>5VX 710</b>	71"	<b>5VX 930</b>	93"	<b>5VX 1400</b>	140"
<b>5VX 550</b>	55"	<b>5VX 730</b>	73"	<b>5VX 950</b>	95"	<b>5VX 1500</b>	150"
<b>5VX 560</b>	56"	<b>5VX 740</b>	74"	<b>5VX 960</b>	96"	<b>5VX 1600</b>	160"
<b>5VX 570</b>	57"	<b>5VX 750</b>	75"	<b>5VX 1000</b>	100"	<b>5VX 1700</b>	170"
<b>5VX 580</b>	58"	<b>5VX 780</b>	78"	<b>5VX 1030</b>	103"	<b>5VX 1800</b>	180"
<b>5VX 590</b>	59"	<b>5VX 800</b>	80"	<b>5VX 1060</b>	106"	<b>5VX 1900</b>	190"
<b>5VX 600</b>	60"	<b>5VX 810</b>	81"	<b>5VX 1080</b>	108"	<b>5VX 2000</b>	200"



## UNIMATCH® BANDED V-BELTS Oil and Heat-Resistant /Static Dissipating

Banded belts are ordered by the required ribs. For example, if 3-ribs are required, then order RB46 1x 3. Price is listed by the rib, so list price is 3x \$12.76 or \$38.28.

### CLASSICAL V-BELTS Part number references belt length in inches based on inside length.

"B" SECTION

Belt Number	Approx Wgt./ Per Rib (Lbs.)	Belt Number	Approx Wgt./ Per Rib (Lbs.)	Belt Number	Approx Wgt./ Per Rib (Lbs.)	Belt Number	Approx Wgt./ Per Rib (Lbs.)
RB46	.70	RB70	.95	RB100	1.36	RB148	2.00
RB48	.70	RB71	.97	RB101	1.34	RB150	2.05
RB51	.70	RB72	.98	RB103	1.39	RB154	2.09
RB52	.70	RB75	1.00	RB105	1.43	RB158	2.14
RB53	.72	RB77	1.02	RB108	1.47	RB160	2.18
RB55	.74	RB78	1.04	RB109	1.50	RB162	2.20
RB56	.75	RB79	1.06	RB112	1.54	RB173	2.35
RB57	.76	RB80	1.08	RB114	1.58	RB180	2.44
RB58	.77	RB81	1.10	RB116	1.61	RB184	2.50
RB59	.79	RB82	1.12	RB118	1.60	RB188	2.68
RB60	.82	RB83	1.15	RB120	1.68	RB190	2.75
RB61	.83	RB85	1.18	RB124	1.75	RB195	2.65
RB62	.84	RB88	1.21	RB128	1.78	RB210	2.85
RB63	.86	RB90	1.22	RB130	1.80	RB225	3.20
RB64	.87	RB93	1.26	RB133	1.81	RB240	3.26
RB65	.88	RB95	1.29	RB136	1.84	RB255	3.46
RB66	.89	RB96	1.30	RB138	1.90	RB270	3.67
RB67	.90	RB97	1.32	RB141	1.92	RB300	4.08
RB68	.92	RB99	1.35	RB144	1.95	RB315	4.28

"C" SECTION

RC60	1.44	RC100	2.40	RC162	3.88	RC285	6.84
RC68	1.65	RC105	2.52	RC173	4.15	RC300	7.20
RC71	1.68	RC109	2.60	RC180	4.32	RC315	7.56
RC75	1.80	RC112	2.68	RC195	4.68	RC330	7.92
RC80	1.85	RC120	2.88	RC204	4.90	RC345	8.28
RC81	1.92	RC126	3.04	RC210	5.04	RC360	8.64
RC85	2.04	RC128	3.07	RC225	5.40	RC390	9.36
RC87	2.09	RC136	3.26	RC240	4.76	RC420	10.80
RC90	2.16	RC144	3.45	RC255	6.12		
RC96	2.30	RC158	3.79	RC270	6.48		

"D" SECTION

RD112	4.7	RD173	7.2	RD270	11.2	RD390	16.2
RD120	5.0	RD180	7.5	RD285	11.8	RD420	17.5
RD128	5.3	RD195	7.9	RD300	12.5	RD480	20.0
RD138	5.8	RD210	8.7	RD315	13.1	RD540	22.5
RD144	6.0	RD225	9.4	RD330	13.7	RD600	25.0
RD158	6.6	RD240	10.0	RD345	14.4	RD660	27.5
RD162	6.8	RD255	10.6	RD360	14.9		

### DEEP-WEDGE V-BELTS Part number references belt length in inches based on outside length.

"3V" SECTION

Belt Number	Approx Wgt./ Per Rib (Lbs.)	Belt Number	Approx Wgt./ Per Rib (Lbs.)	Belt Number	Approx Wgt./ Per Rib (Lbs.)	Belt Number	Approx Wgt./ Per Rib (Lbs.)
R3V355	.2	R3V560	.2	R3V800	.3	R3V1120	.5
R3V400	.2	R3V600	.2	R3V830	.4	R3V1180	.5
R3V425	.2	R3V630	.3	R3V850	.4	R3V1250	.5
R3V450	.2	R3V670	.3	R3V900	.4	R3V1320	.6
R3V475	.2	R3V710	.3	R3V950	.4	R3V1400	.6
R3V500	.2	R3V730	.3	R3V1000	.4		
R3V530	.2	R3V750	.3	R3V1060	.5		

"5V" SECTION

R5V500	.6	R5V900	1.0	R5V1500	1.8	R5V2500	3.0
R5V530	.6	R5V950	1.1	R5V1600	1.9	R5V2650	3.2
R5V560	.7	R5V975	1.2	R5V1650	2.0	R5V2800	3.3
R5V600	.7	R5V1000	1.2	R5V1700	2.0	R5V3000	3.6
R5V630	.7	R5V1060	1.3	R5V1800	2.1	R5V3150	3.8
R5V670	.8	R5V1120	1.3	R5V1900	2.2	R5V3350	4.0
R5V710	.8	R5V1180	1.4	R5V2000	2.4	R5V3550	4.3
R5V750	.8	R5V1250	1.5	R5V2120	2.5		
R5V800	.9	R5V1320	1.6	R5V2240	2.7		
R5V850	.9	R5V1400	1.7	R5V2360	2.8		

"8V" SECTION

R8V1000	3.3	R8V1600	5.2	R8V2360	7.8	R8V3350	11.1
R8V1060	3.5	R8V1650	5.4	R8V2400	8.0	R8V3750	11.7
R8V1120	3.7	R8V1700	5.6	R8V2500	8.3	R8V4000	12.4
R8V1180	3.9	R8V1800	5.9	R8V2650	8.7	R8V4250	13.2
R8V1250	4.1	R8V1900	6.3	R8V2700	9.0	R8V4500	14.0
R8V1320	4.4	R8V2000	6.6	R8V2800	9.2	R8V4750	14.8
R8V1400	4.6	R8V2120	6.9	R8V3000	9.8	R8V5000	16.5
R8V1500	4.9	R8V2240	7.0	R8V3150	9.9	R8V5600	18.4



**DEEP-WEDGE COGGED V-BELTS** Part number references belt length in inches based on outside length.

Belt Number	Approx Wgt./ Per Rib (Lbs.)	Belt Number	Approx Wgt./ Per Rib (Lbs.)	Belt Number	Approx Wgt./ Per Rib (Lbs.)	Belt Number	Approx Wgt./ Per Rib (Lbs.)
R3VX315	.2	R3VX450	.2	R3VX600	.2	R3VX900	.4
R3VX335	.2	R3VX460	.2	R3VX630	.3	R3VX925	.4
R3VX355	.2	R3VX475	.2	R3VX670	.3	R3VX950	.4
R3VX375	.2	R3VX500	.2	R3VX710	.3	R3VX1000	.4
R3VX400	.2	R3VX520	.2	R3VX750	.3	R3VX1060	.5
R3VX425	.2	R3VX530	.2	R3VX800	.3	R3VX1120	.5
R3VX430	.2	R3VX560	.2	R3VX850	.4		

Belt Number	Approx Wgt./ Per Rib (Lbs.)	Belt Number	Approx Wgt./ Per Rib (Lbs.)	Belt Number	Approx Wgt./ Per Rib (Lbs.)	Belt Number	Approx Wgt./ Per Rib (Lbs.)
R5VX500	.6	R5VX630	.7	R5VX830	.9	R5VX1000	1.2
R5VX530	.6	R5VX670	.8	R5VX850	.9	R5VX1060	1.3
R5VX560	.7	R5VX710	.8	R5VX900	1.0		
R5VX600	.7	R5VX750	.8	R5VX950	1.1		

"3VX" SECTION  
"5VX" SECTION

## 4130 PREMIUM RUBBER WATER HOSE

- Machined crush proof brass fittings
- Flexible and abrasion-resistant
- Commercial hose for hot or cold water



PART NUMBER	LENGTH
4130-0062-050BGHT	5/8" x 50'
4130-0062-075BGHT	5/8" x 75'
4130-0075-050BGHT	3/4" x 50'
4130-0075-075BGHT	3/4" x 75'

## V-BELT ACCESSORIES



### V-BELT DISPLAY

Display up to 184 belts at once. 46 hooks hold up to 4 belts each. Display height is 30", width 42", 25" deep. Includes header sign and bracket accessories for easy set up. **Part No. WFD-42**

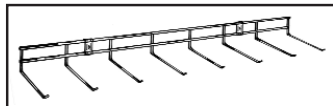

### V-BELT WALL RACK

36" long mounting rack with eight 8" hooks provided. Includes two brackets for quick, easy, durable mounting. **Part No. WHD-7**



### TENSION TESTER GAUGE

Assures proper belt tension and installation. **Part No. TESTER**

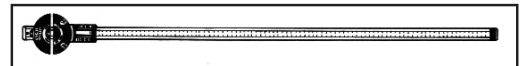

### 110" BELT MEASURER

Measures all size Industrial belts up to 110" in ranges of 3/8", 1/2" and 5/8" accurately and efficiently. **Part No. 32-9108**

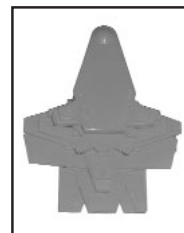

### SHEAVE GAUGE

Can be used to determine both Sheave and Belt size. Check for sheave wear to determine when a replacement is necessary.

**Part No. G001**

# ACCU-LINK<sup>®</sup>

## ADJUSTABLE V-BELTS

FROM

 **Jason Industrial Inc.**<sup>®</sup>  
A MEGADYNE GROUP CO.



## Solve HVAC V-Belt Drive Problems Quickly, Accurately & Permanently!

- The ideal temporary replacement or permanent substitute for conventional rubber V-Belts.
- Easy snap and twist assembly. No special tools!
- Ideal for emergency repairs and replacements. Fits any drive and available in most popular sizes!

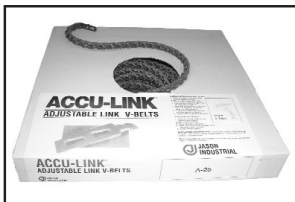

Size	Part No.	Length	Pkg.	List Price
3L	<b>3L-LINK-5</b>	5'	Sleeve	\$72.70
	<b>3L-LINK-25</b>	25'	Carton	\$362.50
	<b>3L-LINK-100</b>	100'	Carton	\$1454.00
A(4L)	<b>AL-LINK-5</b>	5'	Sleeve	\$74.00
	<b>A-LINK-25</b>	25'	Carton	\$370.00
	<b>A-LINK-100</b>	100'	Carton	\$1480.00
B(5L)	<b>BL-LINK-6</b>	6'	Sleeve	\$103.44
	<b>B-LINK-25</b>	25'	Carton	\$431.00
	<b>B-LINK-100</b>	100'	Carton	\$1724.00





# Accu-Link® Adjustable Link V-Belts

## Comparative Length Tables

**Note:**  
Accu-Link® length based on flat measurement of unassembled belt.

### Fractional HP V-Belt

#### Size 3L (3/8") Accu-Link

FHP V-Belt No.	Accu-Link Length	FHP V-Belt No.	Accu-Link Length	FHP V-Belt No.	Accu-Link Length	FHP V-Belt No.	Accu-Link Length	FHP V-Belt No.	Accu-Link Length	FHP V-Belt No.	Accu-Link Length	FHP V-Belt No.	Accu-Link Length
3L140	14"	3L200	20"	3L260	26"	3L320	32"	3L380	38"	3L440	44"	3L500	50"
3L150	15"	3L210	21"	3L270	27"	3L330	33"	3L390	39"	3L450	45"	3L520	52"
3L160	16"	3L220	22"	3L280	28"	3L340	34"	3L400	40"	3L460	46"	3L540	54"
3L170	17"	3L230	23"	3L290	29"	3L350	35"	3L410	41"	3L470	47"	3L560	56"
3L180	18"	3L240	24"	3L300	30"	3L360	36"	3L420	42"	3L480	48"	3L580	58"
3L190	19"	3L250	25"	3L310	31"	3L370	37"	3L430	43"	3L490	49"	3L600	60"

#### Size A (1/2") Accu-Link

FHP V-Belt No.	Accu-Link Length	FHP V-Belt No.	Accu-Link Length	FHP V-Belt No.	Accu-Link Length	FHP V-Belt No.	Accu-Link Length	FHP V-Belt No.	Accu-Link Length	FHP V-Belt No.	Accu-Link Length
A19 (4L210)	21"	A33 (4L350)	35"	A47 (4L490)	49"	A61 (4L630)	63"	A75 (4L770)	77"	A89 (4L910)	91"
A20 (4L220)	22"	A34 (4L360)	36"	A48 (4L500)	50"	A62 (4L640)	64"	A76 (4L780)	78"	A90 (4L920)	92"
A21 (4L230)	23"	A35 (4L370)	37"	A49 (4L510)	51"	A63 (4L650)	65"	A77 (4L790)	79"	A91 (4L930)	93"
A22 (4L240)	24"	A36 (4L380)	38"	A50 (4L520)	52"	A64 (4L660)	66"	A78 (4L800)	80"	A92 (4L940)	94"
A23 (4L250)	25"	A37 (4L390)	39"	A51 (4L530)	53"	A65 (4L670)	67"	A79 (4L810)	81"	A93 (4L950)	95"
A24 (4L260)	26"	A38 (4L400)	40"	A52 (4L540)	54"	A66 (4L680)	68"	A80 (4L820)	82"	A94 (4L960)	96"
A25 (4L270)	27"	A39 (4L410)	41"	A53 (4L550)	55"	A67 (4L690)	69"	A81 (4L830)	83"	A95 (4L970)	97"
A26 (4L280)	28"	A40 (4L420)	42"	A54 (4L560)	56"	A68 (4L700)	70"	A82 (4L840)	84"	A96 (4L980)	98"
A27 (4L290)	29"	A41 (4L430)	43"	A55 (4L570)	57"	A69 (4L710)	71"	A83 (4L850)	85"	A97 (4L990)	99"
A28 (4L300)	30"	A42 (4L440)	44"	A56 (4L580)	58"	A70 (4L720)	72"	A84 (4L860)	86"	A98 (4L1000)	100"
A29 (4L310)	31"	A43 (4L450)	45"	A57 (4L590)	59"	A71 (4L730)	73"	A85 (4L870)	87"	A99	101"
A30 (4L320)	32"	A44 (4L460)	46"	A58 (4L600)	60"	A72 (4L740)	74"	A86 (4L880)	88"		
A31 (4L330)	33"	A45 (4L470)	47"	A59 (4L610)	61"	A73 (4L750)	75"	A87 (4L890)	89"		
A32 (4L340)	34"	A46 (4L480)	48"	A60 (4L620)	62"	A74 (4L760)	76"	A88 (4L900)	90"		

#### Size B (21/32") Accu-Link

FHP V-Belt No.	Accu-Link Length	FHP V-Belt No.	Accu-Link Length	FHP V-Belt No.	Accu-Link Length	FHP V-Belt No.	Accu-Link Length	FHP V-Belt No.	Accu-Link Length	FHP V-Belt No.	Accu-Link Length
B22 (5L250)	25"	B35 (5L380)	38"	B48 (5L510)	51"	B61 (5L640)	64"	B74 (5L770)	77"	B87 (5L900)	90"
B23 (5L260)	26"	B36 (5L390)	39"	B49 (5L520)	52"	B62 (5L650)	65"	B75 (5L780)	78"	B88 (5L910)	91"
B24 (5L270)	27"	B37 (5L400)	40"	B50 (5L530)	53"	B63 (5L660)	66"	B76 (5L790)	79"	B89 (5L920)	92"
B25 (5L280)	28"	B38 (5L410)	41"	B51 (5L540)	54"	B64 (5L670)	67"	B77 (5L800)	80"	B90 (5L930)	93"
B26 (5L290)	29"	B39 (5L420)	42"	B52 (5L550)	55"	B65 (5L680)	68"	B78 (5L810)	81"	B91 (5L940)	94"
B27 (5L300)	30"	B40 (5L430)	43"	B53 (5L560)	56"	B66 (5L690)	69"	B79 (5L820)	82"	B92 (5L950)	95"
B28 (5L310)	31"	B41 (5L440)	44"	B54 (5L570)	57"	B67 (5L700)	70"	B80 (5L830)	83"	B93 (5L960)	96"
B29 (5L320)	32"	B42 (5L450)	45"	B55 (5L580)	58"	B68 (5L710)	71"	B81 (5L840)	84"	B94 (5L970)	97"
B30 (5L330)	33"	B43 (5L460)	46"	B56 (5L590)	59"	B69 (5L720)	72"	B82 (5L850)	85"	B95 (5L980)	98"
B31 (5L340)	34"	B44 (5L470)	47"	B57 (5L600)	60"	B70 (5L730)	73"	B83 (5L860)	86"	B96 (5L990)	99"
B32 (5L350)	35"	B45 (5L480)	48"	B58 (5L610)	61"	B71 (5L740)	74"	B84 (5L870)	87"	B97	100"
B33 (5L360)	36"	B46 (5L490)	49"	B59 (5L620)	62"	B72 (5L750)	75"	B85 (5L880)	88"	B98	101"
B34 (5L370)	37"	B47 (5L500)	50"	B60 (5L630)	63"	B73 (5L760)	76"	B86 (5L890)	89"	B99	102"

Note: Accu-Link® lengths are approximate. Adjustments may be required (links removed) after initial run-in.

# DRIVE BELT NOMENCLATURE

V-Belt Type	Numbered By	Part Number	Outside Length
Length Fractional HP Classical Multi-Plus Fractional HP Classical Multi-Plus Classical Cogged Narrow Deep Wedge	Outside Length	<b>4L500</b>	= <b>50"</b>
	Inside Length	<b>A48</b>	= <b>50"</b>
	Outside Length	<b>5L500</b>	= <b>50"</b>
	Inside Length	<b>B47</b>	= <b>50"</b>
	Inside Length	<b>AX48</b>	= <b>50"</b>
	Outside Length	<b>5VX500</b>	= <b>50"</b>

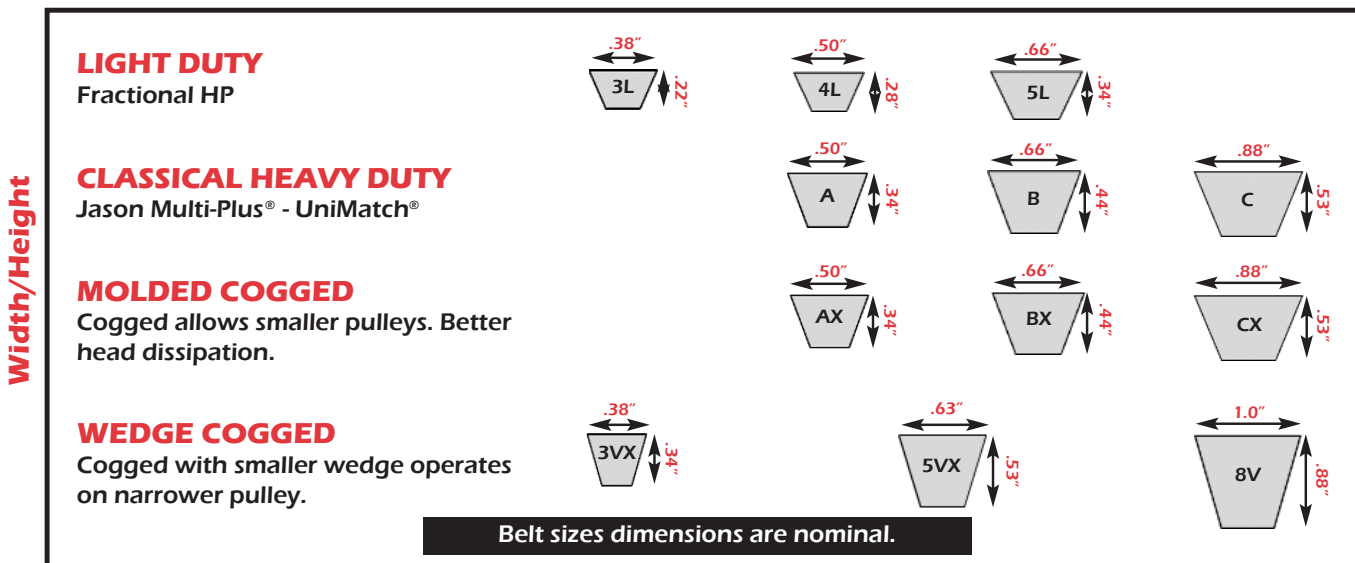

## 1. Cover - Rubberized Fabric

- Flexible, non-cracking, smooth running for long life.
- Oil, heat & abrasion resistant.

## 2. Load Section - Polyester Cords

- Positioned to take tension in both FHP & Classical applications.
- Chemically treated, then fused prevents separation.

## 3. Load Carrying Section

- Special compound to resist stretch & fatigue.

## 4. Compression Section

- Elastomer resists compression fatigue.
- Dissipates internal heat build-up.
- Provides firm lateral pressure against groove sidewall and distributes the load to cords.

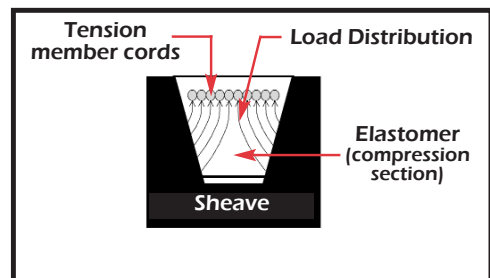
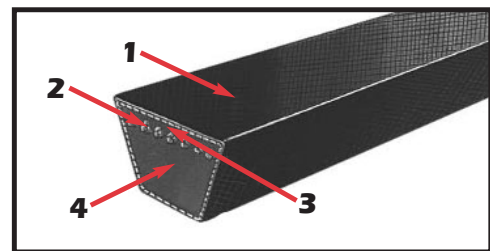

# TECHNICAL DATA

## Belt Tensioning

V-Belt tensioning adjustment should be made using a tension meter or gauge, using the following procedure - seat the belt into groove and adjust center distance to take up slack. Operate the belt under load and increase tension further until only a slight bow on the slack side of the belt is apparent. Stop the drive and, using the tension meter, measure the force necessary to depress the belt 1/64" for every inch of belt span.

$$\text{Tension} = 1/64 \times \text{belt span.}$$

V-Belt deflection forces may vary from the initial run in at belt installation.

## Belt Length Formula

- Motor Sheave Diameter (DR) + Driven (DN) Sheave Diameter x 1.57
- Add (2x) Center Distance, between DR and DN shafts
- Equals the belt's "Effective Length"

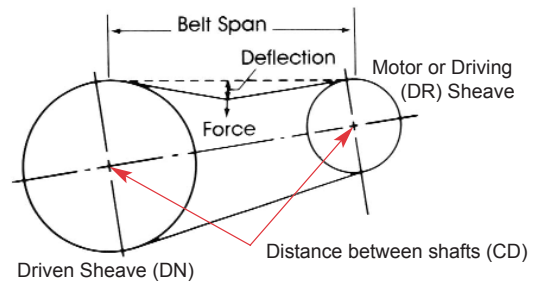

# BELT WEAR/FAILURE RECOGNITION



**Exposure to Oil & Grease**  
**Cause:** Belt swelling, exterior softness and bottom envelope seam to open/split.  
**Remedy:** Splash Guards, don't over-lubricate, clean belts/sheaves.



**Weathering or "Crazing"**  
**Cause:** Belt drive elements, as well as aggravation by small sheaves.  
**Remedy:** Check tension, provide drive protection and replace belt(s).

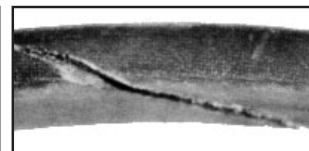

**Cut Bottom & Sidewall**  
**Cause:** Belt being pried over sheave during installation, as cut above indicates.  
**Remedy:** Use proper length belts and tension properly when installing.



**Severe Localized Wear**  
**Cause:** Spin burn caused by a frozen or locked drive sheave not able to turn freely.  
**Remedy:** Determine that drive components turn freely and, if necessary, tighten belt.



**Rough Sheave Sidewalls**  
**Cause:** Constant slippage due to belt being misaligned on worn sheaves.  
**Remedy:** Use correct belt size. Align or replace sheaves.



**Broken Belt**  
**Cause:** Rough sheaves and dust build-up can both cause belt failure and severe envelope wear.  
**Remedy:** Shield the drive.



**Snub Break**  
**Cause:** Cover wear indicates slippage and clean break reveals sudden snap due to non-proper drive tensioning.  
**Remedy:** Maintain proper drive tension.

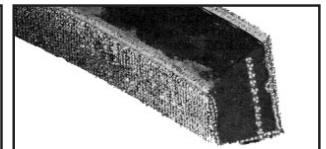

**Abrasion**  
**Cause:** Sidewall wear a result of foreign material and rust in sheaves. Belt dropped to bottom of sheave groove.  
**Remedy:** Dust guards to prevent abrasion.

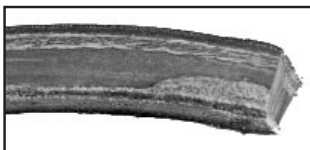

**Worn Side Pattern**  
**Cause:** Worn or misaligned sheaves.  
**Remedy:** Retension drive to stop slipping, realign sheaves (replace if needed), replace belt if incorrect size.



**Oil Deterioration**  
**Cause:** Rubber softened by excessive oil exposure, causing deterioration.  
**Remedy:** Splash guards to protect drive against oil.

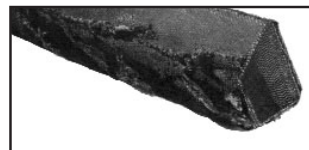

**Cover Fabric Rupture**  
**Cause:** Fabric covering ruptured during installation due to belt being pried over belt sheave.  
**Remedy:** Proper installation of belts.

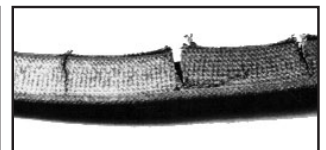

**Base Cracking**  
**Cause:** Loose tensioning. Belt slippage causes heat build-up and gradual under-cord hardening.  
**Remedy:** New belt. Proper tensioning.

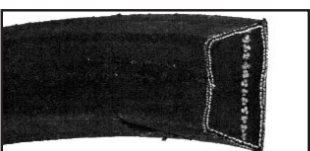

**Distorted Belt**  
**Cause:** Distortion caused by broken cords or adhesion breakdown.  
**Remedy:** Avoid prying on belts. Check sheaves for recommended diameters.

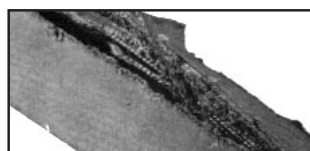

**Ply Separation**  
**Cause:** Split along pitch line indicating belt ran on too small diameter of sheave.  
**Remedy:** Install a (x) cogged type belt.

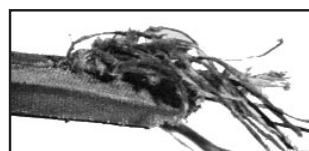

**Ruptured Belt**  
**Cause:** Ruptured cords in the plies, caused by high shock load on foreign object between belt and sheave groove.  
**Remedy:** Check tension, shield drive.



**Slip Burn**  
**Cause:** Belt slipping under starting or stalling load.  
**Remedy:** Replace belt and tighten drives until slipping stops.

**AK SHEAVES - FOR 3L, 4L & A Belts**



**AK - Bored to Size**

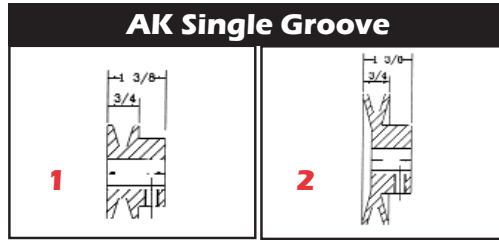

**AK PACKAGED**

Out Side	Datum Dia			Draw Type	Bore Size											Wt. Lbs.	
	"A" Datum	"3L" Datum	"A" Datum		1/2"	5/8"	3/4"	7/8"	15/16"	1"	1-1/8"	1-3/16"	1-7/16"				
1.75	1.50	1.16	1	AK17-1/2	AK17-5/8	AK17-3/4											.2
2.00	1.80	1.46	1	AK20-1/2	AK20-5/8	AK20-3/4	AK20-7/8										.3
2.10	1.90	1.56	1	AK21-1/2	AK21-5/8	AK21-3/4	AK21-7/8										.4
2.20	2.00	1.66	1	AK22-1/2	AK22-5/8	AK22-3/4	AK22-7/8										.5
2.30	2.10	1.76	1	AK23-1/2	AK23-5/8	AK23-3/4	AK23-7/8		AK23-1								.5
2.50	2.30	1.96	2	AK25-1/2	AK25-5/8	AK25-3/4	AK25-7/8		AK25-1	AK25-1-1/8							.5
2.60	2.40	2.06	2	AK26-1/2	AK26-5/8	AK26-3/4	AK26-7/8		AK26-1								.5
2.70	2.50	2.16	2	AK27-1/2	AK27-5/8	AK27-3/4	AK27-7/8		AK27-1								.6
2.80	2.60	2.26	2	AK28-1/2	AK28-5/8	AK28-3/4	AK28-7/8		AK28-1	AK28-1-1/8							.7
3.05	2.80	2.46	2	AK30-1/2	AK30-5/8	AK30-3/4	AK30-7/8		AK30-1	AK30-1-1/8							.7
3.25	3.00	2.66	2	AK32-1/2	AK32-5/8	AK32-3/4	AK32-7/8		AK32-1	AK32-1-1/8							.7
3.45	3.20	2.86	2	AK34-1/2	AK34-5/8	AK34-3/4	AK34-7/8		AK34-1	AK34-1-1/8							.9
3.75	3.50	3.16	2	AK39-1/2	AK39-5/8	AK39-3/4	AK39-7/8	AK39-15/16	AK39-1	AK39-1-1/8							1.4
3.95	3.70	3.36	2	AK41-1/2	AK41-5/8	AK41-3/4	AK41-7/8	AK41-15/16	AK41-1	AK41-1-1/8							1.5
4.25	4.00	3.66	1	AK44-1/2	AK44-5/8	AK44-3/4	AK44-7/8	AK44-15/16	AK44-1	AK44-1-1/8							1.5
4.45	4.20	3.86	1	AK46-1/2	AK46-5/8	AK46-3/4	AK46-7/8	AK46-15/16	AK46-1	AK46-1-1/8							1.5
4.75	4.50	4.16	1	AK49-1/2	AK49-5/8	AK49-3/4	AK49-7/8	AK49-15/16	AK49-1	AK49-1-1/8							1.7
4.95	4.70	4.36	1	AK51-1/2	AK51-5/8	AK51-3/4	AK51-7/8	AK51-15/16	AK51-1	AK51-1-1/8	AK51-1-3/16						1.7
5.25	5.00	4.66	1	AK54-1/2	AK54-5/8	AK54-3/4	AK54-7/8	AK54-15/16	AK54-1	AK54-1-1/8	AK54-1-3/16						1.8
5.45	5.20	4.86	1	AK56-1/2	AK56-5/8	AK56-3/4	AK56-7/8	AK56-15/16	AK56-1	AK56-1-1/8	AK56-1-3/16						1.9
5.75	5.50	5.16	1	AK59-1/2	AK59-5/8	AK59-3/4	AK59-7/8	AK59-15/16	AK59-1	AK59-1-1/8	AK59-1-3/16						2.0
5.95	5.70	5.36	1	AK61-1/2	AK61-5/8	AK61-3/4	AK61-7/8	AK61-15/16	AK61-1	AK61-1-1/8	AK61-1-3/16						2.1
6.25	6.00	5.66	1	AK64-1/2	AK64-5/8	AK64-3/4	AK64-7/8	AK64-15/16	AK64-1	AK64-1-1/8	AK64-1-3/16						2.2
6.45	6.20	5.86	1	AK66-1/2	AK66-5/8	AK66-3/4	AK66-7/8		AK66-1	AK66-1-1/8	AK66-1-3/16						2.3
6.95	6.70	6.36	1	AK71-1/2	AK71-5/8	AK71-3/4	AK71-7/8		AK71-1	AK71-1-1/8	AK71-1-3/16	AK71-1-7/16					3.8
7.25	7.00	6.66	1	AK74-1/2	AK74-5/8	AK74-3/4	AK74-7/8	AK74-15/16	AK74-1	AK74-1-1/8	AK74-1-3/16	AK74-1-7/16					3.4
7.75	7.50	7.16	3			AK79-3/4			AK79-1								3.5
8.25	8.00	7.66	1	AK84-1/2	AK84-5/8	AK84-3/4		AK84-15/16	AK84-1			AK84-1-7/16					3.8
9.25	9.00	8.66	1	AK94-1/2	AK94-5/8	AK94-3/4		AK94-15/16	AK94-1			AK94-1-7/16					4.5
10.25	10.00	9.66	1	AK104-1/2	AK104-5/8	AK104-3/4			AK104-1			AK104-1-7/16					5.1
10.75	10.50	10.16	1			AK109-3/4			AK109-1			AK109-1-7/16					5.8
12.25	12.00	11.66	3		AK124-5/8												7.0
13.25	13.00	12.66	1			AK134-3/4			AK134-1			AK134-1-7/16					7.5
14.25	14.00	13.66	1			AK144-3/4			AK144-1			AK144-1-7/16					8.5
2.00	1.80	1.46	1			2AK20-3/4											1.0
2.25	2.00	1.66	1	2AK22-1/2	2AK22-5/8	2AK22-3/4	2AK22-7/8										.9
2.35	2.10	1.76	1	2AK23-1/2													1.0
2.55	2.30	1.96	1	2AK25-1/2	2AK25-5/8	2AK25-3/4	2AK25-7/8		2AK25-1								1.3
2.75	2.50	2.16	1		2AK27-5/8	2AK27-3/4	2AK27-7/8		2AK27-1								1.5
2.85	2.60	2.26	1	2AK28-1/2	2AK28-5/8	2AK28-3/4	2AK28-7/8		2AK28-1								1.8
3.05	2.80	2.46	1	2AK30-1/2	2AK30-5/8	2AK30-3/4	2AK30-7/8		2AK30-1	2AK30-1-1/8							1.8
3.25	3.00	2.66	1		2AK32-5/8	2AK32-3/4	2AK32-7/8		2AK32-1	2AK32-1-1/8							2.1
3.45	3.20	2.86	1	2AK34-1/2	2AK34-5/8	2AK34-3/4	2AK34-7/8		2AK34-1	2AK34-1-1/8							2.3
3.75	3.50	3.16	2		2AK39-5/8	2AK39-3/4	2AK39-7/8		2AK39-1	2AK39-1-1/8							2.6
3.95	3.70	3.36	2		2AK41-5/8	2AK41-3/4	2AK41-7/8		2AK41-1	2AK41-1-1/8							2.9
4.25	4.00	3.66	2		2AK44-5/8	2AK44-3/4	2AK44-7/8		2AK44-1	2AK44-1-1/8							3.0
4.45	4.20	3.86	2		2AK46-5/8		2AK46-7/8		2AK46-1	2AK46-1-1/8							3.1
4.75	4.50	4.16	2			2AK49-3/4	2AK49-7/8		2AK49-1	2AK49-1-1/8							3.6
4.95	4.70	4.36	2		2AK51-5/8	2AK51-3/4	2AK51-7/8		2AK51-1	2AK51-1-1/8							3.8
5.25	5.00	4.66	2		2AK54-5/8	2AK54-3/4	2AK54-7/8		2AK54-1	2AK54-1-1/8							3.3
5.45	5.20	4.86	1		2AK56-5/8	2AK56-3/4			2AK56-1	2AK56-1-1/8							3.4
5.75	5.50	5.16	1			2AK59-3/4			2AK59-1	2AK59-1-1/8							3.5
5.95	5.70	5.36	1			2AK61-3/4	2AK61-7/8		2AK61-1	2AK61-1-1/8							3.6
6.25	6.00	5.66	1			2AK64-3/4			2AK64-1	2AK64-1-1/8	2AK64-1-3/16	2AK64-1-7/16					4.8
7.25	7.00	6.66	1			2AK74-3/4			2AK74-1	2AK74-1-1/8	2AK74-1-3/16	2AK74-1-7/16					5.6
8.25	8.00	7.66	3						2AK84-1								8.0
10.25	10.00	9.66	3					2AK104-15/16	2AK104-1								10

## AK SHEAVES - FOR 3L, 4L & A Belts



**AK BUSHED**

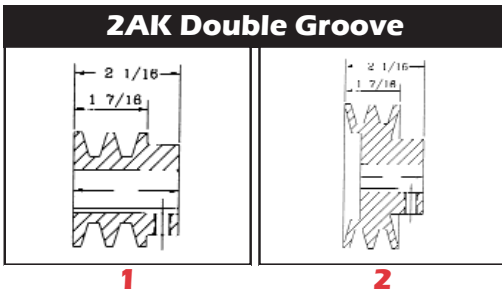

- Light Duty Cast Iron Sheaves
- Machined from Gray Cast Iron
- Statically Balanced and Painted
- Individually Packaged

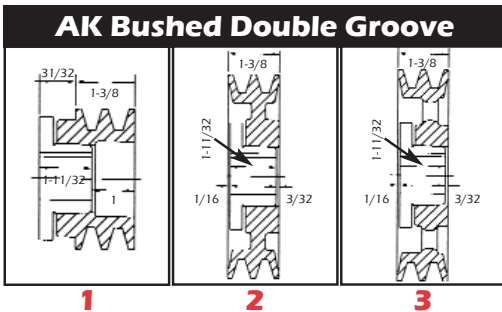
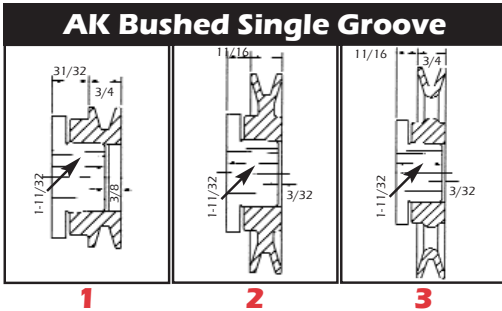

Item	Bushing Type	Outside	"A" Datum	"3L" Datum	Drawing	Wt. Lbs.
AK30H	H	3.05	2.80	2.46	1	1.10
AK32H	H	3.25	3.00	2.66	1	1.20
AK34H	H	3.45	3.20	2.86	2	1.00
AK39H	H	3.75	3.50	3.16	2	1.40
AK41H	H	3.95	3.70	3.36	2	1.60
AK44H	H	4.25	4.00	3.66	2	1.90
AK46H	H	4.45	4.20	3.86	2	1.90
AK49H	H	4.75	4.50	4.16	2	2.10
AK51H	H	4.95	4.70	4.36	2	2.30
AK54H	H	5.25	5.00	4.66	2	2.00
AK56H	H	5.45	5.20	4.86	2	2.30
AK59H	H	5.75	5.50	5.16	2	2.40
AK61H	H	5.95	5.70	5.36	3	2.50
AK64H	H	6.25	6.00	5.66	3	2.70
AK66H	H	6.45	6.20	5.86	3	2.80
AK69H	H	6.75	6.50	6.16	3	3.20
AK71H	H	6.95	6.70	6.36	3	3.10
AK74H	H	7.25	7.00	6.66	3	3.30
AK79H	H	7.75	7.50	7.16	3	3.50
AK84H	H	8.25	8.00	7.66	3	3.60
AK89H	H	8.75	8.50	8.16	3	4.00
AK94H	H	9.25	9.00	8.66	3	4.40
AK99H	H	9.75	9.50	9.16	3	4.70
AK104H	H	10.25	10.00	9.66	3	5.1
AK109H	H	10.75	10.5	10.16	3	6.1
AK134H	H	13.25	13	12.66	3	7.4
2AK30H	H	3.05	2.80	2.46	1	1.40
2AK32H	H	3.25	3.00	2.66	1	1.70
2AK34H	H	3.45	3.20	2.86	1	1.80
2AK39H	H	3.75	3.50	3.16	2	1.80
2AK41H	H	3.95	3.70	3.36	2	1.90
2AK44H	H	4.25	4.00	3.66	2	2.40
2AK46H	H	4.45	4.20	3.86	2	2.50
2AK49H	H	4.75	4.50	4.16	2	3.10
2AK51H	H	4.95	4.70	4.36	2	3.20
2AK54H	H	5.25	5.00	4.66	2	3.40
2AK56H	H	5.45	5.20	4.86	3	3.60
2AK59H	H	5.75	5.50	5.16	3	3.40
2AK61H	H	5.95	5.70	5.36	3	3.30
2AK64H	H	6.25	6.00	5.66	3	3.90
2AK74H	H	7.25	7.00	6.66	3	4.90
2AK84H	H	8.25	8.00	7.66	3	5.80
2AK94H	H	9.25	9.00	8.66	3	6.10
2AK104H	H	10.25	10.00	9.66	3	7.70

**H-Bushings for AK/BK Sheaves**

**Bushing Nomenclature**

**H - 1/2**

Bushing Type      Bore Size

- H-3/8
- H-7/16
- H-1/2
- H-9/16
- H-5/8
- H-11/16
- H-3/4
- H-13/16
- H-7/8
- H-15/16
- H-1
- H-1-1/16
- H-1-1/8
- H-1-3/16
- H-1-1/4
- H-1-5/16
- H-1-3/8
- H-1-7/16
- H-1-1/2

**Order Bushings Separately**

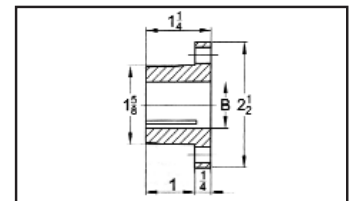

**See page 31 for Bore Sizes and Keyseat**



**BK SHEAVES - FITS 4L, A & 5L, B Belts**

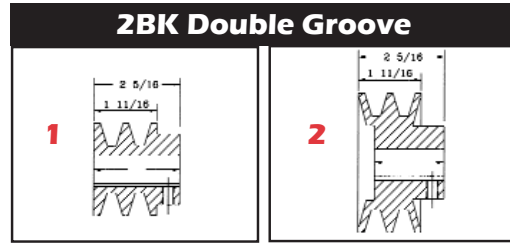
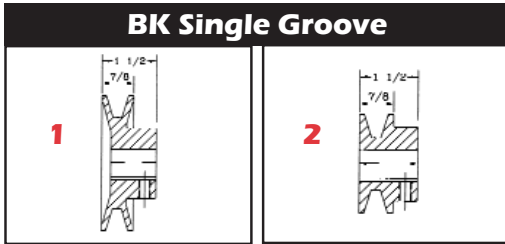

Dia. Out Side	Datum Dia.		Draw No.	Bore Size										Wt. Lbs.			
	"A"	"B"		1/2"	5/8"	3/4"	7/8"	15/16"	1"	1-1/8"	1-3/16"	1-3/8"	1-7/16"				
2.40	1.65	2.05	1	BK24-1/2	BK24-5/8												.1
2.50	1.90	2.30	1	BK25-1/2	BK25-5/8	BK25-3/4	BK25-7/8			BK25-1							.5
2.60	2.00	2.40	1	BK26-1/2	BK26-5/8	BK26-3/4	BK26-7/8										.6
2.70	2.10	2.50	2	BK27-1/2	BK27-5/8	BK27-3/4	BK27-7/8			BK27-1							.6
2.95	2.20	2.60	2	BK28-1/2	BK28-5/8	BK28-3/4	BK28-7/8			BK28-1	BK28-1-1/8						.8
3.15	2.40	2.80	2	BK30-1/2	BK30-5/8	BK30-3/4	BK30-7/8										.8
3.35	2.60	3.00	2	BK32-1/2	BK32-5/8	BK32-3/4	BK32-7/8										.8
3.55	2.80	3.20	2	BK34-1/2	BK34-5/8	BK34-3/4	BK34-7/8			BK34-1	BK34-1-1/8						1.3
3.75	3.00	3.40	2	BK36-1/2	BK36-5/8	BK36-3/4	BK36-7/8			BK36-1	BK36-1-1/8						1.5
3.95	3.20	3.60	2	BK40-1/2	BK40-5/8	BK40-3/4	BK40-7/8			BK40-1	BK40-1-1/8						1.5
4.25	3.50	3.90	2	BK45-1/2	BK45-5/8	BK45-3/4	BK45-7/8			BK45-1	BK45-1-1/8						1.8
4.45	3.70	4.10	2	BK47-1/2	BK47-5/8	BK47-3/4	BK47-7/8			BK47-1	BK47-1-1/8						1.9
4.75	4.00	4.40	2	BK50-1/2	BK50-5/8	BK50-3/4	BK50-7/8			BK50-1	BK50-1-1/8						2.0
4.95	4.20	4.60	2	BK52-1/2	BK52-5/8	BK52-3/4	BK52-7/8			BK52-1	BK52-1-1/8						2.0
5.25	4.50	4.90	2	BK55-1/2	BK55-5/8	BK55-3/4	BK55-7/8			BK55-1	BK55-1-1/8	BK55-1-3/16					2.2
5.75	5.00	5.40	2	BK60-1/2	BK60-5/8	BK60-3/4	BK60-7/8			BK60-1	BK60-1-1/8						2.5
5.95	5.20	5.60	2	BK62-1/2	BK62-5/8	BK62-3/4	BK62-7/8			BK62-1	BK62-1-1/8	BK62-1-3/16					2.4
6.45	5.70	6.10	2			BK65-3/4	BK65-7/8										3.0
6.45	5.70	6.10	2		BK67-5/8	BK67-3/4	BK67-7/8			BK67-1	BK67-1-1/8						2.8
6.75	6.00	6.40	2		BK70-5/8	BK70-3/4	BK70-7/8			BK70-1	BK70-1-1/8	BK70-1-3/16			BK70-1-7/16		3.3
6.95	6.20	6.60	2			BK72-3/4	BK72-7/8			BK72-1	BK72-1-1/8						3.9
7.25	6.50	6.90	2							BK75-1							3.5
7.75	7.00	7.40	2		BK80-5/8	BK80-3/4				BK80-1							4.0
8.25	7.50	7.90	2			BK85-3/4											4.5
8.75	8.00	8.40	2		BK90-5/8	BK90-3/4				BK90-1							5.0
9.25	8.50	8.90	2			BK95-3/4											5.5
9.75	9.00	9.40	2	BK100-1/2		BK100-3/4	BK100-7/8			BK100-1	BK100-1-1/8	BK100-1-3/16	BK100-1-3/8	BK100-1-7/16			5.6
10.25	9.50	9.90	2							BK105-1							6.0
10.75	10.00	10.40	2			BK110-3/4				BK110-1	BK110-1-1/8	BK110-1-3/16	BK110-1-3/8	BK110-1-7/16			6.4
11.25	10.50	10.90	2							BK115-1	BK115-1-1/8		BK115-1-3/8	BK115-1-7/16			6.9
11.75	11.40	11.75	2			BK120-3/4				BK120-1							8.0
12.75	12.40	12.75	2			BK130-3/4				BK130-1							9.0
13.75	13.00	13.40	2			BK140-3/4				BK140-1							10
15.75	15.00	15.40	2							BK160-1	BK160-1-1/8	BK160-1-3/16	BK160-1-3/8	BK160-1-7/16			11.4
2.50	1.90	2.30	1	2BK25-1/2	2BK25-5/8	2BK25-3/4	2BK25-7/8										1.3
2.70	2.10	2.50	1	2BK27-1/2	2BK27-5/8		2BK27-7/8			2BK27-1							1.6
2.95	2.20	2.60	1	2BK28-1/2	2BK28-5/8	2BK28-3/4	2BK28-7/8			2BK28-1	2BK28-1-1/8						1.9
3.15	2.40	2.80	1	2BK30-1/2	2BK30-5/8	2BK30-3/4	2BK30-7/8			2BK30-1	2BK30-1-1/8						2.3
3.35	2.60	3.00	1	2BK32-1/2	2BK32-5/8		2BK32-7/8			2BK32-1	2BK32-1-1/8						2.6
3.55	2.80	3.20	1		2BK34-5/8	2BK34-3/4	2BK34-7/8			2BK34-1	2BK34-1-1/8						2.8
3.75	3.00	3.40	1			2BK36-3/4	2BK36-7/8			2BK36-1	2BK36-1-1/8						3.3
3.95	3.20	3.60	2		2BK40-5/8	2BK40-3/4	2BK40-7/8			2BK40-1	2BK40-1-1/8		2BK36-1-3/8				3.3
4.25	3.50	3.90	2							2BK45-1	2BK45-1-1/8		2BK45-1-3/8				3.3
4.45	3.70	4.10	2				2BK47-7/8			2BK47-1	2BK47-1-1/8						3.7
4.75	4.00	4.40	2			2BK50-3/4				2BK50-1	2BK50-1-1/8		2BK50-1-3/8				4.1
4.95	4.20	4.60	2		2BK52-5/8		2BK52-7/8			2BK52-1	2BK52-1-1/8		2BK52-1-3/8				4.5
5.25	4.50	4.90	2							2BK55-1	2BK55-1-1/8						4.5
5.75	5.00	5.40	2			2BK60-3/4	2BK60-7/8			2BK60-1	2BK60-1-1/8						5.0
5.95	5.20	5.60	2		2BK62-5/8					2BK62-1							6.0
6.75	6.00	6.40	2		2BK70-5/8												6.0
7.75	7.00	7.40	2		2BK80-5/8	2BK80-3/4				2BK80-1		2BK80-1-3/16					7.0
8.75	8.00	8.40	2		2BK90-5/8						2BK90-1-1/8						8.0
9.75	9.00	9.40	2			2BK100-3/4				2BK100-1		2BK100-1-3/16					10
10.75	10.0	10.40	2							2BK110-1							13
11.75	11.0	11.40	2					2BK120-15/16		2BK120-1		2BK120-1-3/16					10
13.75	13.0	13.4	2							2BK140-1							17

## BK SHEAVES - FITS 4L, A & 5L, B Belts



**BK BUSHED**

- Light Duty Cast Iron Sheaves
- Machined from Gray Cast Iron
- Statically Balanced and Painted
- Individually Packaged

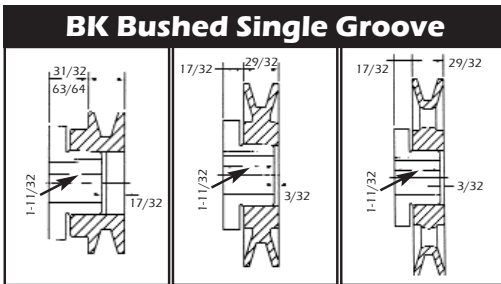

### BK Bushed Double Groove

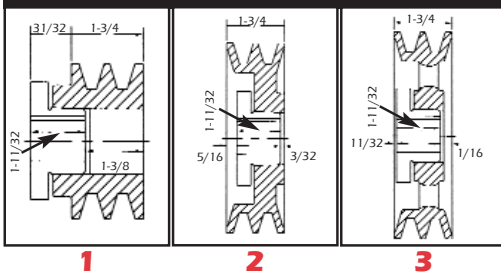

See page 31 for  
Complete  
H-Bushing  
Bore Sizes

Item	Bushing Type	Outside	"A" Datum	"B" Datum	Drawing	Wt. Lbs.
BK30H	H	3.15	2.40	2.80	1	1.20
BK32H	H	3.35	2.60	3.00	1	1.40
BK34H	H	3.55	2.80	3.20	1	1.60
BK36H	H	3.75	3.00	3.40	1	1.20
BK40H	H	3.95	3.20	3.60	1	1.40
BK45H	H	4.25	3.50	3.90	1	1.80
BK47H	H	4.45	3.70	4.10	1	2.20
BK50H	H	4.75	4.00	4.40	2	2.00
BK52H	H	4.95	4.20	4.60	2	2.10
BK55H	H	5.25	4.50	4.90	2	2.70
BK57H	H	5.45	4.70	5.10	2	2.70
BK60H	H	5.75	5.00	5.40	3	2.50
BK62H	H	5.95	5.20	5.60	3	2.60
BK65H	H	6.25	5.50	5.90	3	2.80
BK67H	H	6.45	5.70	6.10	3	2.90
BK70H	H	6.75	6.00	6.40	3	2.80
BK72H	H	6.95	6.20	6.60	3	3.10
BK75H	H	7.25	6.50	6.90	3	3.30
BK77H	H	7.45	6.70	7.10	3	3.80
BK80H	H	7.75	7.00	7.40	3	3.40
BK85H	H	8.25	7.50	7.90	3	3.80
BK90H	H	8.75	8.00	8.40	3	4.30
BK95H	H	9.25	8.50	8.90	3	5.00
BK100H	H	9.75	9.00	9.40	3	5.20
BK105H	H	10.25	9.50	9.90	3	5.50
BK110H	H	10.75	10.00	10.40	3	6.00
BK115H	H	11.25	10.50	10.90	3	6.40
BK120H	H	11.75	11.00	11.40	3	6.90
BK130H	H	12.75	12.00	12.40	3	6.90
BK140H	H	13.75	13.00	13.40	3	8.50
BK150H	H	14.75	14.00	14.40	3	9.50
BK160H	H	15.75	15.00	15.40	3	9.80
BK190H	H	18.75	18.00	18.40	3	12.80
2BK32H	H	3.35	2.60	3.00	1	2.10
2BK34H	H	3.55	2.80	3.20	1	2.40
2BK36H	H	3.75	3.00	3.40	1	2.00
2BK40H	H	3.95	3.20	3.60	2	2.40
2BK45H	H	4.25	3.50	3.90	2	3.00
2BK47H	H	4.45	3.70	4.10	2	2.80
2BK50H	H	4.75	4.00	4.40	2	3.30
2BK52H	H	4.95	4.20	4.60	2	3.60
2BK55H	H	5.25	4.50	4.90	2	3.90
2BK57H	H	5.45	4.70	5.10	2	4.30
2BK60H	H	5.75	5.00	5.40	3	4.40
2BK62H	H	5.95	5.20	5.60	3	4.50
2BK65H	H	6.25	5.50	5.90	3	4.50
2BK67H	H	6.45	5.70	6.10	3	5.00
2BK70H	H	6.75	6.00	6.40	3	5.10
2BK80H	H	7.75	7.00	7.40	3	6.40
2BK90H	H	8.75	8.00	8.40	3	7.60
2BK100H	H	9.75	9.00	9.40	3	8.40
2BK110H	H	10.75	10.00	10.40	3	9.30
2BK120H	H	11.75	11.00	11.40	3	11.00
2BK130H	H	12.75	12.00	12.40	3	13.10
2BK140H	H	13.75	13.00	13.40	3	14.80
2BK160H	H	15.75	15.00	15.40	3	17.50
2BK190H	H	18.75	18.00	18.40	3	21.50

### Standard Keyseat

Bore Range	Keyseat
1/2"	None
5/8 to 7/8	3/16" x 3/32"
1 1/16 to 1-3/16	1/4 x 1/8
1-3/8	5/16 x 5/32
1-7/16	3/8 x 3/16

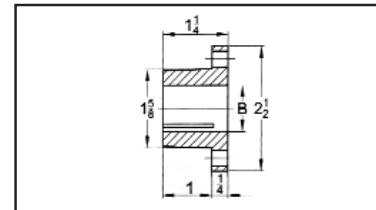

**VARIABLE PITCH SHEAVES**  
Fits 3L, 4L, 5L, A, or B Belts

Dia Pitch Out Side	Datum Dia			Bore Size								Wt. Lbs.	
	3L Belts	"A" Belts	5" or "B" Belts	1/2"	5/8"	3/4"	7/8"	1"	1-1/8"	1-3/8"	1-5/8"		
2.50	1.6-2.4			1VL25-1/2	1VL25-5/8								0.8
2.87	1.8-2.7			1VL30-1/2	1VL30-5/8								1.0
3.15	1.7-2.5	1.9-2.9	2.4-3.2	1VL34-1/2*	1VL34-5/8*	1VL34-3/4							1.1
3.75	2.3-3.1	2.4-3.4	2.7-3.7	1VL40-1/2	1VL40-5/8	1VL40-3/4	1VL40-7/8						1.3
4.15	2.7-3.5	2.8-3.8	3.1-4.1	1VL44-1/2	1VL44-5/8	1VL44-3/4	1VL44-7/8						1.3
4.75	3.3-4.1	3.4-4.4	3.7-4.7		1VM50-5/8		1VM50-7/8						2.8
2.32	1.4-2.2			1VP25-1/2									0.7
3.15	1.7-2.5	1.9-2.9	2.4-3.2	1VP34-1/2	1VP34-5/8								1.4
3.75	2.3-3.1	2.4-3.4	2.7-3.7		1VP40-5/8	1VP40-3/4							1.9
4.15	2.7-3.5	2.8-3.8	3.1-4.1	1VP44-1/2	1VP44-5/8	1VP44-3/4							2.4
4.15	2.7-3.5	2.8-3.8	3.1-4.1				1VP44-7/8	1VP44-1	1VP44-1-1/8				2.9
4.75	3.3-3.4	3.4-4.4	3.7-4.7	1VP50-1/2	1VP50-5/8	1VP50-3/4	1VP50-7/8	1VP50-1	1VP50-1-1/8				2.9
4.75	3.3-3.4	3.4-4.4	3.7-4.7										3.6
5.35	3.9-4.7	4.0-5.0	4.3-5.3	1VP56-1/2	1VP56-5/8	1VP56-3/4							3.8
5.35	3.9-4.7	4.0-5.0	4.3-5.3				1VP56-7/8	1VP56-1	1VP56-1-1/8				4.4
6.00		4.2-5.2	4.3-5.5				1VP60-7/8		1VP60-1-1/8	1VP60-1-3/8			6.5
5.95	4.5-5.3	4.6-5.6	4.9-5.9				1VP62-7/8	1VP62-1	1VP62-1-1/8	1VP62-1-3/8			6.1
6.50		4.7-5.7	4.8-6.0				1VP65-7/8		1VP65-1-1/8	1VP65-1-3/8			6.8
6.55	5.1-5.9	5.2-6.2	5.5-6.5				1VP68-7/8	1VP68-1	1VP68-1-1/8	1VP68-1-3/8			7.3
7.10		5.3-6.3	5.4-6.6				1VP71-7/8		1VP71-1-1/8	1VP71-1-3/8			8.2
7.50		5.7-6.7	5.8-7.0				1VP75-7/8		1VP75-1-1/8	1VP75-1-3/8			9.2
3.35	1.9-2.7	2.0-3.0	2.5-3.3		2VP36-5/8	2VP36-3/4	2VP36-7/8						3.4
3.95	2.5-3.3	2.6-3.6	2.9-3.9		2VP42-5/8	2VP42-3/4	2VP42-7/8	2VP42-1	2VP42-1-1/8				4.4
4.75	3.3-4.1	3.4-4.4	3.7-4.7		2VP50-5/8	2VP50-3/4	2VP50-7/8	2VP50-1	2VP50-1-1/8				6.3
5.35	3.9-4.7	4.0-5.0	4.3-5.3		2VP56-5/8	2VP56-3/4	2VP56-7/8	2VP56-1	2VP56-1-1/8				7.8
6.00		4.2-5.2	4.3-5.5			2VP60-3/4	2VP60-7/8	2VP60-1	2VP60-1-1/8	2VP60-1-3/8	2VP60-1-5/8		10.6
5.95	4.5-5.3	4.6-5.6	4.9-5.9				2VP62-7/8		2VP62-1-1/8	2VP62-1-3/8			10
6.50		4.7-5.7	4.8-6.0						2VP65-1-1/8	2VP65-1-3/8	2VP65-1-5/8		12.3
6.55	5.1-5.9	5.2-6.2	5.5-6.5						2VP68-1-1/8	2VP68-1-3/8	2VP68-1-5/8		11.7
7.10		5.3-6.3	5.4-6.6						2VP71-1-1/8	2VP71-1-3/8	2VP71-1-5/8		14.6
7.50		5.7-6.7	5.8-7.0						2VP75-1-1/8	2VP75-1-3/8	2VP75-1-5/8		16.5

\* For 2 Set Screws, add "2SS" after part number

See Page 32 for Variable Pitch Length Diameter Chart

**Bored to Size**



1VP



2VP

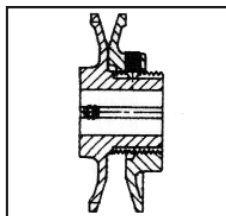

- 1VP - Single Groove Pulley
- 2VP - 2-Groove Pulley
- Includes Hollow Head Set Screws and Keyseat
- Use standard Jason sheaves as a companion sheave.

**AL (BLOWER) SHEAVES**

Diameter Outside	A-Datum	Bore Size			Wt. Lbs.
		5/8"	3/4"	1"	
4.93	4.78	AL54-5/8	AL54-3/4	AL54-1	1.1
5.93	5.78	AL64-5/8	AL64-3/4	AL64-1	1.2
6.93	6.78	AL74-5/8	AL74-3/4	AL74-1	1.5
7.93	7.78	AL84-5/8	AL84-3/4	AL84-1	1.8
7.93	7.78			AL84-1-Y	1.8
8.93	8.78		AL94-3/4	AL94-1	2.4
9.93	9.78		AL104-3/4	AL104-1	2.9
10.93	10.78		AL114-3/4	AL114-1	3.1
11.93	11.78		AL124-3/4	AL124-1	3.8



- Light Duty Applications
- Includes Set Screw and Keyseat
- Cast Aluminum

Not to Be Used with "AX" Notched Belt Rated Drives

- Heavy Duty Applications
- Statically Balanced and Painted
- Individually Packaged

## QD SHEAVES & BUSHINGS "A/B" Combination



**QD "B" SHEAVE**



**QD SHEAVE PACKAGING**

- Individually packaged
- Sealed in plastic wrap

### Standard Keyseat

Bore Range	Keyseat
1/2" - 9/16"	1/8" x 1/16"
5/8" - 7/8"	3/16" x 3/32"
15/16" - 1-1/4"	1/4" x 1/8"
1-5/16" - 1-3/8"	5/16" x 5/32"
1-7/16" - 1-3/4"	3/8" x 3/16"
1-13/16" - 2-1/4"	1/2" x 1/4"
2-5/16" - 2-3/4"	5/8" x 5/16"
2-13/16" - 3-1/4"	3/4" x 3/8"
3-3/8" - 3-3/4"	7/8" x 7/16"
3-7/8" - 4-1/4"	1" x 1/2"

**1-GROOVE ("F" DIMENSION = 7/8" up to 7.15 O.D. & 1" after)**

Diameter Outside	"A" Datum	"B" Datum	One Groove	Bushing Type	Drawing	"H"	"L"	"E"	Wt. Lbs.
3.75	3	3.4	1B34SH	SH	11B	1/2"	1-1/4"	1/8"	1
3.95	3.2	3.6	1B36SH	SH	11B	1/2"	1-1/4"	1/8"	1
4.15	3.4	3.8	1B38SH	SH	11B	1/2"	1-1/4"	1/8"	2
4.35	3.6	4	1B40SH	SH	11B	1/2"	1-1/4"	1/8"	2
4.55	3.8	4.2	1B42SH	SH	11B	1/2"	1-1/4"	1/8"	2
4.75	4	4.4	1B44SH	SH	11B	1/2"	1-1/4"	1/8"	2
4.95	4.2	4	1B46SDS	SDS	5B	7/16"	1-15/16"	0	2
5.15	4.4	4.8	1B48SDS	SDS	5B	7/16"	1-15/16"	0	3
5.35	4.6	5	1B50SDS	SDS	5B	7/16"	1-15/16"	0	3
5.55	4.8	5.2	1B52SDS	SDS	5B	7/16"	1-15/16"	0	3
5.75	5	5.4	1B54SDS	SDS	5B	7/16"	1-15/16"	0	4
5.95	5.2	5.6	1B56SDS	SDS	5B	7/16"	1-15/16"	0	4
6.15	5.4	5.8	1B58SDS	SDS	5B	7/16"	1-15/16"	0	4
6.35	5.6	6	1B60SDS	SDS	5B	7/16"	1-15/16"	0	5
6.55	5.8	6.2	1B62SDS	SDS	5B	7/16"	1-15/16"	0	5
6.75	6	6.4	1B64SDS	SDS	5B	7/16"	1-15/16"	0	6
6.95	6.2	6.6	1B66SDS	SDS	5B	7/16"	1-15/16"	0	6
7.15	6.4	6.8	1B68SDS	SDS	5B	7/16"	1-15/16"	0	6
7.35	6.6	7	1B70SDS	SDS	6A	9/16"	1-15/16"	1/4"	6
7.75	7	7.4	1B74SDS	SDS	6A	9/16"	1-15/16"	1/4"	6
8.35	7.6	8	1B80SDS	SDS	6A	9/16"	1-15/16"	1/4"	7
8.95	8.2	8.6	1B86SDS	SDS	6A	9/16"	1-15/16"	1/4"	8
9.35	8.6	9	1B90SDS	SDS	6A	9/16"	1-15/16"	1/4"	9
9.75	9	9	1B94SDS	SDS	6A	9/16"	1-15/16"	1/4"	9
11.35	10.6	11	1B110SDS	SDS	6A	9/16"	1-15/16"	1/4"	11
12.75	12	12.4	1B124SDS	SDS	6A	9/16"	1-15/16"	1/4"	12
13.95	13.2	13.6	1B136SDS	SDS	6A	9/16"	1-15/16"	1/4"	13
15.75	15	15.4	1B154SK	SK	5A	11/16"	1-7/8"	3/16"	20
16.35	15.6	16	1B160SK	SK	5A	7/8"	1-7/8"	0	22
18.75	18	18.4	1B184SK	SK	5A	15/16"	1-7/8"	1/16"	28
20.35	19.6	20	1B200SK	SK	5A	13/16"	1-7/8"	1/16"	30
25.35	24.6	25	1B250SK	SK	5A	15/16"	1-7/8"	1/16"	40

**2-GROOVE ("F" DIMENSION = 1-3/4")**

Diameter Outside	"A" Datum	"B" Datum	Two Groove	Bushing Type	Drawing	"H"	"L"	"E"	Wt. Lbs.
3.75	3	3.4	2B34SH	SH	11B	5/8"	1-1/4"	1-1/8"	2
3.95	3.2	3.6	2B36SH	SH	11B	15/32"	1-1/4"	31/32"	3
4.15	3.4	3.8	2B38SH	SH	11B	15/32"	1-1/4"	31/32"	3
4.35	3.6	4	2B40SH	SH	11B	15/32"	1-1/4"	31/32"	3
4.55	3.8	4.2	2B42SH	SH	1B	1/16"	1-1/4"	7/16"	3
4.75	4	4.4	2B44SH	SH	1B	1/16"	1-1/4"	7/16"	4
4.95	4.2	4	2B46SDS	SDS	4B	0	1-5/16"	7/16"	4
5.15	4.4	4.8	2B48SDS	SDS	4B	0	1-5/16"	7/16"	4
5.35	4.6	5	2B50SDS	SDS	4B	0	1-5/16"	7/16"	5
5.55	4.8	5.2	2B52SDS	SDS	4B	0	1-5/16"	7/16"	5
5.75	5	5.4	2B54SDS	SDS	4B	0	1-5/16"	7/16"	6
5.95	5.2	5.6	2B56SDS	SDS	4B	0	1-5/16"	7/16"	6
6.15	5.4	5.8	2B58SDS	SDS	4B	0	1-5/16"	7/16"	6
6.35	5.6	6	2B60SDS	SDS	4W	0	1-5/16"	7/16"	6
6.55	5.8	6.2	2B62SDS	SDS	4W	0	1-5/16"	7/16"	7
6.75	6	6.4	2B64SDS	SDS	4W	0	1-5/16"	7/16"	7
6.95	6.2	6.6	2B66SDS	SDS	4W	0	1-5/16"	7/16"	8
7.15	6.4	6.8	2B68SDS	SDS	4W	0	1-5/16"	7/16"	8
7.35	6.6	7	2B70SK	SK	6W	3/8"	1-7/8"	1/4"	9
7.75	7	7.4	2B74SK	SK	6W	3/8"	1-7/8"	1/4"	10
8.35	7.6	8	2B80SK	SK	6W	3/8"	1-7/8"	1/4"	11
8.95	8.2	8.6	2B86SK	SK	6A	3/8"	1-7/8"	1/4"	12
9.35	8.6	9	2B90SK	SK	6A	3/8"	1-7/8"	1/4"	12
9.75	9	9.4	2B94SK	SK	6A	3/8"	1-7/8"	1/4"	13
11.35	10.6	11	2B110SK	SK	6A	3/8"	1-7/8"	1/4"	15
12.75	12	12.4	2B124SK	SK	6A	9/16"	1-7/8"	7/16"	18
13.95	13.2	13.6	2B136SK	SK	6A	3/8"	1-7/8"	1/4"	24
15.75	15	15.4	2B154SK	SK	6A	3/8"	1-7/8"	1/4"	25
16.35	15.6	16	2B160SK	SK	6A	3/8"	1-7/8"	1/4"	27.4
18.75	18	18.4	2B184SK	SK	6A	3/8"	1-7/8"	1/4"	38
20.35	19.6	20	2B200SF	SF	6A	11/16"	2"	7/16"	47
25.35	24.6	25	2B250SF	SF	5A	3/8"	2"	1/8"	60
30.35	29.6	30	2B300SF	SF	6A	7/16"	2"	3/16"	75
38.35	37.6	38	2B380SF	SF	6A	11/32"	2"	3/32"	100

See pages 18 & 19 for Drawing Type diagrams.

- Heavy Duty Applications
- Statically Balanced and Painted
- Individually Packaged

**QD SHEAVES & BUSHINGS**  
**"A/B" Combination**

**3-GROOVE ("F" DIMENSION = 2-1/2")**

Diameter Outside	"A" Datum	"B" Datum	Three Groove	Bushing Type	Drawing	"H"	"L"	"E"	Wt. Lbs.
3.75	3	3.4	3B34SH	SH	11B	5/8"	1-1/4"	1-7/8"	3
3.95	3.2	3.6	3B36SH	SH	11B	5/8"	1-1/4"	1-7/8"	4
4.15	3.4	3.8	3B38SH	SH	11B	5/8"	1-1/4"	1-7/8"	4
4.35	3.6	4	3B40SH	SH	11B	5/8"	1-1/4"	1-7/8"	4
4.55	3.8	4.2	3B42SH	SH	11B	7/16"	1-1/4"	13/16"	4
4.75	4	4.4	3B44SH	SH	1B	7/16"	1-1/4"	13/16"	5
4.95	4.2	4	3B46SD	SD	1B	3/8"	1-13/16"	5/16"	5
5.15	4.4	4.8	3B48SD	SD	1B	3/8"	1-13/16"	5/16"	6
5.35	4.6	5	3B50SD	SD	1B	3/8"	1-13/16"	5/16"	7
5.55	4.8	5.2	3B52SD	SD	1B	3/8"	1-13/16"	5/16"	7
5.75	5	5.4	3B54SD	SD	1B	3/8"	1-13/16"	5/16"	8
5.95	5.2	5.6	3B56SD	SD	1B	3/8"	1-13/16"	5/16"	9
6.15	5.4	5.8	3B58SD	SD	1W	3/8"	1-13/16"	5/16"	9
6.35	5.6	6	3B60SD	SD	1W	3/8"	1-13/16"	5/16"	10
6.55	5.8	6.2	3B62SD	SD	1W	3/8"	1-13/16"	5/16"	10
6.75	6	6.4	3B64SD	SD	1W	3/8"	1-13/16"	5/16"	10
6.95	6.2	6.6	3B66SD	SD	1W	3/8"	1-13/16"	5/16"	10
7.15	6.4	6.8	3B68SD	SD	1W	3/8"	1-13/16"	5/16"	11
7.35	6.6	7	3B70SK	SK	6W	1/8"	1-7/8"	3/4"	12
7.75	7	7.4	3B74SK	SK	6W	1/8"	1-7/8"	3/4"	12
8.35	7.6	8	3B80SK	SK	6W	1/8"	1-7/8"	3/4"	13
8.95	8.2	8.6	3B86SK	SK	6A	1/8"	1-7/8"	3/4"	14
9.35	8.6	9	3B90SK	SK	6A	1/8"	1-7/8"	3/4"	15
9.75	9	9	3B94SK	SK	6A	1/8"	1-7/8"	3/4"	17
11.35	10.6	11	3B110SK	SK	6A	1/8"	1-7/8"	3/4"	21
12.75	12	12.4	3B124SK	SK	6A	1/8"	1-7/8"	3/4"	25
13.95	13.2	13.6	3B136SK	SK	6A	1/8"	1-7/8"	3/4"	28
15.75	15	15.4	3B154SK	SK	6A	1/8"	1-7/8"	3/4"	30
16.35	15.6	16	3B160SK	SK	6A	1/8"	1-7/8"	3/4"	32
18.75	18	18.4	3B184SK	SK	6A	1/8"	1-7/8"	3/4"	41
20.35	19.6	20	3B200SF	SF	4A	3/16"	2"	11/16"	55.6
25.35	24.6	25	3B250SF	SF	4A	3/16"	2"	11/16"	76.1
30.35	29.6	30	3B300SF	SF	4A	3/16"	2"	11/16"	96
38.35	37.6	38	3B380E	E	6A	3/8"	2-5/8"	1/4"	145

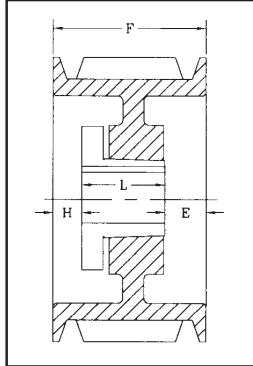

**DRAWING TYPE 1**  
(1A, 1B, 1W)

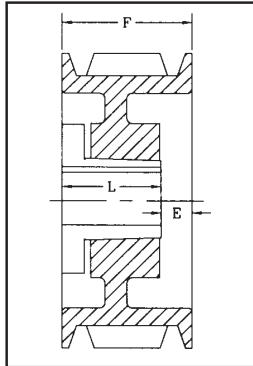

**DRAWING TYPE 4**  
(4A, 4B, 4W)

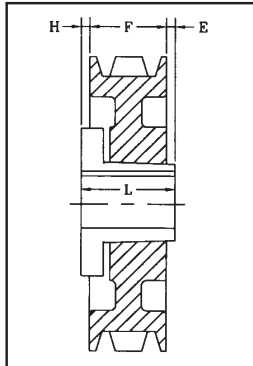

**DRAWING TYPE 5**  
(5A, 5B)

**4-GROOVE ("F" DIMENSION = 3-1/4")**

Diameter Outside	"A" Pitch	"B" Pitch	Four Groove	Bushing Type	Drawing	"H"	"L"	"E"	Wt. Lbs.
3.75	3	3.4	4B34SD	SD	10B	1"	1-13/16"	2-7/16"	4
3.95	3.2	3.6	4B36SD	SD	10B	1"	1-13/16"	2-7/16"	5
4.15	3.4	3.8	4B38SD	SD	10B	1"	1-13/16"	2-7/16"	6
4.35	3.6	4	4B40SD	SD	11B	11/16"	1-13/16"	2-1/8"	5
4.55	3.8	4.2	4B42SD	SD	11B	11/16"	1-13/16"	2-1/8"	6
4.75	4	4.4	4B44SD	SD	11B	11/16"	1-13/16"	2-1/8"	6
4.95	4.2	4	4B46SD	SD	11B	5/8"	1-13/16"	13/16"	7
5.15	4.4	4.8	4B48SD	SD	1B	5/8"	1-13/16"	13/16"	8
5.35	4.6	5	4B50SD	SD	1B	5/8"	1-13/16"	13/16"	8
5.55	4.8	5.2	4B52SD	SD	1B	5/8"	1-13/16"	13/16"	9
5.75	5	5.4	4B54SD	SD	1B	5/8"	1-13/16"	13/16"	10
5.95	5.2	5.6	4B56SD	SD	1B	5/8"	1-13/16"	13/16"	10
6.15	5.4	5.8	4B58SD	SD	1W	5/8"	1-13/16"	13/16"	11
6.35	5.6	6	4B60SD	SD	1W	5/8"	1-13/16"	13/16"	11
6.55	5.8	6.2	4B62SD	SD	1W	5/8"	1-13/16"	13/16"	12
6.75	6	6.4	4B64SD	SD	1W	5/8"	1-13/16"	13/16"	11
6.95	6.2	6.6	4B66SD	SD	1W	5/8"	1-13/16"	13/16"	11
7.15	6.4	6.8	4B68SD	SD	1W	5/8"	1-13/16"	13/16"	12
7.35	6.6	7	4B70SK	SK	1W	3/16"	1-7/8"	1-3/16"	13
7.75	7	7.4	4B74SK	SK	1W	3/16"	1-7/8"	1-3/16"	15
8.35	7.6	8	4B80SK	SK	1W	3/16"	1-7/8"	1-3/16"	15
8.95	8.2	8.6	4B86SK	SK	1A	3/16"	1-7/8"	1-3/16"	17
9.35	8.6	9	4B90SK	SK	1A	3/16"	1-7/8"	1-3/16"	17
9.75	9	9	4B94SK	SK	1A	3/16"	1-7/8"	1-3/16"	19
11.35	10.6	11	4B110SK	SK	1A	3/16"	1-7/8"	1-3/16"	25
12.75	12	12.4	4B124SK	SK	1A	3/16"	1-7/8"	1-3/16"	28
13.95	13.2	13.6	4B136SK	SK	1A	3/16"	1-7/8"	13/16"	32
15.75	15	15.4	4B154SF	SF	1A	3/16"	2"	1-1/16"	38
16.35	15.6	16	4B160SF	SF	1A	3/16"	2"	1-1/16"	41
18.75	18	18.4	4B184SF	SF	1A	3/16"	2"	1-1/16"	48
20.35	19.6	20	4B200SF	SF	1A	3/16"	2"	1-1/16"	60
25.35	24.6	25	4B250E	E	6A	1/16"	2-5/8"	11/16"	93
30.35	29.6	30	4B300E	E	6A	1/16"	2-5/8"	11/16"	120
38.35	37.6	38	4B380E	E	1A	0	2-5/8"	5/8"	162



- Heavy Duty Applications
- Statically Balanced and Painted
- Individually Packaged

## QD SHEAVES & BUSHINGS "A/B" Combination

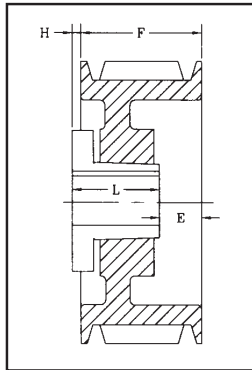

**DRAWING  
TYPE 6  
(6A, 6W)**

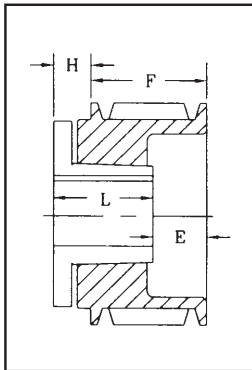

**DRAWING  
TYPE 10  
(10B)**

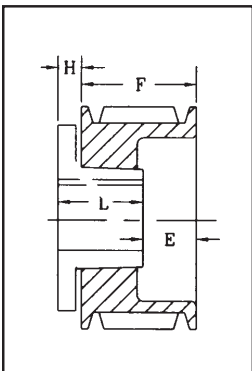

**DRAWING  
TYPE 11  
(11B)**

Diameter Outside	"A" Datum	"B" Datum	Five Groove	Bushing Type	Drawing	"H"	"L"	"E"	Wt. Lbs.
3.75	3	3.4	5B34SD	SD	10B	1"	1-13/16"	3-3/16"	5
3.95	3.2	3.6	5B36SD	SD	10B	1"	1-13/16"	3-3/16"	6
4.15	3.4	3.8	5B38SD	SD	10B	1"	1-13/16"	3-3/16"	6
4.35	3.6	4	5B40SD	SD	11B	1 1/16"	1-13/16"	2-7/8"	6
4.55	3.8	4.2	5B42SD	SD	11B	1 1/16"	1-13/16"	2-7/8"	7
4.75	4	4.4	5B44SD	SD	11B	1 1/16"	1-13/16"	2-7/8"	7
4.95	4.2	4	5B46SD	SD	1B	5/8"	1-13/16"	1-9/16"	7
5.15	4.4	4.8	5B48SD	SD	1B	5/8"	1-13/16"	1-9/16"	9
5.35	4.6	5	5B50SD	SD	1B	5/8"	1-13/16"	1-9/16"	10
5.55	4.8	5.2	5B52SD	SD	1B	5/8"	1-13/16"	1-9/16"	10
5.75	5	5.4	5B54SK	SK	1B	1/2"	1-7/8"	1-5/8"	10
5.95	5.2	5.6	5B56SK	SK	1B	1/2"	1-7/8"	1-5/8"	11
6.15	5.4	5.8	5B58SK	SK	1B	1/2"	1-7/8"	1-5/8"	12
6.35	5.6	6	5B60SK	SK	1B	1/2"	1-7/8"	1-5/8"	12
6.55	5.8	6.2	5B62SK	SK	1B	1/2"	1-7/8"	1-5/8"	14
6.75	6	6.4	5B64SK	SK	1B	1/2"	1-7/8"	1-5/8"	14
6.95	6.2	6.6	5B66SK	SK	1B	1/2"	1-7/8"	1-5/8"	15
7.15	6.4	6.8	5B68SK	SK	1B	1/2"	1-7/8"	1-5/8"	16
7.35	6.6	7	5B70SF	SF	1B	1/2"	2"	1-1/2"	16
7.75	7	7.4	5B74SF	SF	1B	1/2"	2"	1-1/2"	18
8.35	7.6	8	5B80SF	SF	1W	1/2"	2"	1-1/2"	19
8.95	8.2	8.6	5B86SF	SF	1W	1/2"	2"	1-1/2"	21
9.35	8.6	9	5B90SF	SF	1A	1/2"	2"	1-1/2"	21
9.75	9	9	5B94SF	SF	1A	1/2"	2"	1-1/2"	22
11.35	10.6	11	5B110SF	SF	1A	1/2"	2"	1-1/2"	29
12.75	12	12.4	5B124SF	SF	1A	1/2"	2"	1-1/2"	33
13.95	13.2	13.6	5B136SF	SF	1A	1/2"	2"	1-1/2"	39
15.75	15	15.4	5B154SF	SF	1A	1/2"	2"	1-1/2"	43
16.35	15.6	16	5B160SF	SF	1A	1/2"	2"	1-1/2"	46
18.75	18	18.4	5B184SF	SF	1A	1/2"	2"	1-1/2"	54
20.35	19.6	20	5B200E	E	1A	3/16"	2-5/8"	1-3/16"	77.5
25.35	24.6	25	5B250E	E	1A	3/16"	2-5/8"	1-3/16"	108
30.35	29.6	30	5B300E	E	1A	3/16"	2-5/8"	1-3/16"	131
38.35	37.6	38	5B380E	E	1A	3/16"	2-3/8"	1-3/16"	169

Diameter Outside	"A" Pitch	"B" Pitch	Six Groove	Bushing Type	Drawing	"H"	"L"	"E"	Wt. Lbs.
3.75	3	3.4	6B34SD	SD	10B	1-3/32"	1-13/16"	4-1/32"	6
3.95	3.2	3.6	6B36SD	SD	10B	1-3/32"	1-13/16"	4-1/32"	7
4.15	3.4	3.8	6B38SD	SD	10B	1-3/32"	1-13/16"	4-1/32"	7
4.35	3.6	4	6B40SD	SD	11B	1 1/16"	1-13/16"	3-5/8"	7
4.55	3.8	4.2	6B42SD	SD	11B	1 1/16"	1-13/16"	3-5/8"	8
4.75	4	4.4	6B44SD	SD	11B	1 1/16"	1-13/16"	3-5/8"	9
4.95	4.2	4	6B46SD	SD	1B	5/8"	1-13/16"	2-5/16"	9
5.15	4.4	4.8	6B48SD	SD	1B	5/8"	1-13/16"	2-5/16"	10
5.35	4.6	5	6B50SD	SD	1B	5/8"	1-13/16"	2-5/16"	11
5.55	4.8	5.2	6B52SD	SD	1B	5/8"	1-13/16"	2-5/16"	11
5.75	5	5.4	6B54SK	SK	1B	1/2"	1-7/8"	2-3/8"	11
5.95	5.2	5.6	6B56SK	SK	1B	1/2"	1-7/8"	2-3/8"	13.4
6.15	5.4	5.8	6B58SK	SK	1B	1/2"	1-7/8"	2-3/8"	15.5
6.35	5.6	6	6B60SK	SK	1B	1/2"	1-7/8"	2-3/8"	15
6.55	5.8	6.2	6B62SK	SK	1B	1/2"	1-7/8"	2-3/8"	15
6.75	6	6.4	6B64SK	SK	1B	1/2"	1-7/8"	2-3/8"	16
6.95	6.2	6.6	6B66SK	SK	1B	1/2"	1-7/8"	2-3/8"	17
7.15	6.4	6.8	6B68SK	SK	1B	1/2"	1-7/8"	2-3/8"	18
7.35	6.6	7	6B70SF	SF	1B	7/8"	2"	1-7/8"	19
7.75	7	7.4	6B74SF	SF	1B	7/8"	2"	1-7/8"	20
8.35	7.6	8	6B80SF	SF	1W	7/8"	2"	1-7/8"	24
8.95	8.2	8.6	6B86SF	SF	1W	7/8"	2"	1-7/8"	26
9.75	9	9	6B94SF	SF	1W	7/8"	2"	1-7/8"	30
11.35	10.6	11	6B110SF	SF	1A	7/8"	2"	1-7/8"	30
12.75	12	12.4	6B124SF	SF	1A	7/8"	2"	1-7/8"	37
13.95	13.2	13.6	6B136SF	SF	1A	1-3/32"	2"	1-21/32"	39
15.75	15	15.4	6B154SF	SF	1A	1-3/32"	2"	1-21/32"	51.4
16.35	15.6	16	6B160SF	SF	1A	7/8"	2"	1-7/8"	54.6
18.75	18	18.4	6B184SF	SF	1A	1-3/32"	2"	1-21/32"	59
20.35	19.6	20	6B200E	E	1A	3/16"	2-5/8"	1-15/16"	96.9
25.35	24.6	25	6B250E	E	1A	5/16"	2-5/8"	1-13/16"	120
30.35	29.6	30	6B300E	E	1A	5/16"	2-5/8"	1-13/16"	151
38.35	37.6	38	6B380E	E	1A	5/16"	2-5/8"	1-13/16"	157

**QD SHEAVES & BUSHINGS**  
**"C" Section**

1-GROOVE ("F" DIMENSION = 1-3/8")	Diameter Outside	"C" Datum	One Groove	Bushing Type	Drawing	"H"	"L"	"E"	Wt. Lbs.
	7.4	7	1C70SF	SF	5B	9/16"	2.0"	1/16"	10
	7.9	7.5	1C75SF	SF	5B	9/16"	2.0"	1/16"	11
	8.4	8	1C80SF	SF	5B	9/16"	2.0"	1/16"	13.2
	8.9	8.5	1C85SF	SF	5B	9/16"	2.0"	1/16"	15.6
	9.4	9	1C90SF	SF	5W	19/32"	2.0"	1/32"	13
	9.9	9.5	1C95SF	SF	5W	19/32"	2.0"	1/32"	18
	10.4	10	1C100SF	SF	5W	11/16"	2.0"	1/16"	14
	10.9	10.5	1C105SF	SF	5W	11/16"	2.0"	1/16"	20
	11.4	11	1C110SF	SF	5W	17/32"	2.0"	3/32"	15
12.4	12	1C120SF	SF	5W	11/16"	2.0"	1/16"	16	
13.4	13	1C130SF	SF	6A	11/16"	2.0"	1/16"	18	
14.4	14	1C140SF	SF	6A	11/16"	2.0"	1/16"	20	
16.4	16	1C160SF	SF	6A	11/16"	2.0"	1/16"	24	
18.4	18	1C180SF	SF	6A	11/16"	2.0"	1/16"	32	
20.4	20	1C200SF	SF	6A	11/16"	2.0"	1/16"	35	
24.4	24	1C240SF	SF	6A	11/16"	2.0"	1/16"	46.9	

- Heavy Duty Applications
- Statically Balanced and Painted
- Individually Packaged

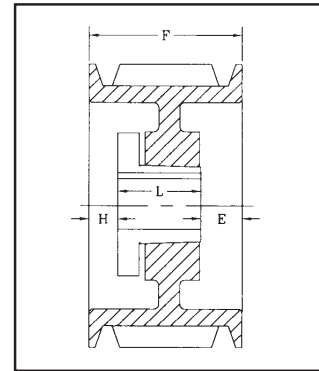

**DRAWING TYPE 1 (1A, 1B, 1W)**

2-GROOVE ("F" DIMENSION = 2-3/8")	Diameter Outside	"C" Datum	Two Groove	Bushing Type	Drawing	"H"	"L"	"E"	Wt. Lbs.
	6.4	6	2C60SF	SF	1B	1/16"	2.0"	5/16"	11
	7.4	7	2C70SF	SF	1B	0"	2.0"	3/8"	13
	7.9	7.5	2C75SF	SF	1B	0"	2.0"	3/8"	15
	8.4	8	2C80SF	SF	1B	0"	2.0"	3/8"	17
	8.9	8.5	2C85SF	SF	1B	0"	2.0"	3/8"	19
	9.4	9	2C90SF	SF	1W	0"	2.0"	3/8"	21
	9.9	9.5	2C95SF	SF	1W	0"	2.0"	3/8"	22
	10.4	10	2C100SF	SF	1W	0"	2.0"	3/8"	21.8
	10.9	10.5	2C105SF	SF	1W	0"	2.0"	3/8"	23
11.4	11	2C110SF	SF	1W	0"	2.0"	9/16"	26	
12.4	12	2C120SF	SF	6W	1/4"	2.0"	5/8"	37	
13.4	13	2C130SF	SF	6A	1/4"	2.0"	5/8"	35	
14.4	14	2C140SF	SF	6A	1/4"	2.0"	5/8"	40	
16.4	16	2C160SF	SF	6A	1/4"	2.0"	5/8"	40	
18.4	18	2C180SF	SF	6A	1/4"	2.0"	5/8"	50	
20.4	20	2C200SF	SF	6A	1/4"	2.0"	5/8"	55	
24.4	24	2C240SF	SF	6A	1/4"	2.0"	5/8"	73.1	
27.4	27	2C270F	F	5A	29/32"	3-5/8"	11/32"	94	
30.4	30	2C300F	F	5A	29/32"	3-5/8"	11/32"	104	

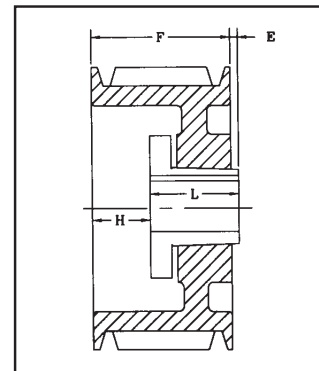

**DRAWING TYPE 2 (2A, 2B, 2W)**

3-GROOVE ("F" DIMENSION = 3-3/8")	Diameter Outside	"C" Datum	Three Groove	Bushing Type	Drawing	"H"	"L"	"E"	Wt. Lbs.
	5.4	5	3C50SD	SD	1B	15/16"	1-13/16"	1-1/4"	9
	5.4	5.6	3C56SD	SD	1B	5/16"	1-13/16"	1-1/4"	10
	6.4	6	3C60SF	SF	1B	1/16"	2.0"	1-5/16"	11.3
	7.4	7	3C70SF	SF	1B	1/2"	2.0"	7/8"	16
	7.9	7.5	3C75SF	SF	1B	1/2"	2.0"	7/8"	18
	8.4	8	3C80E	E	2B	11/16"	2-5/8"	1/16"	21
	8.9	8.5	3C85E	E	2B	11/16"	2-5/8"	1/16"	24
	9.4	9	3C90E	E	2B	11/16"	2-5/8"	1/16"	26
	9.9	9.5	3C95E	E	2W	11/16"	2-5/8"	1/16"	29.8
10.4	10	3C100E	E	2W	11/16"	2-5/8"	1/16"	34	
10.9	10.5	3C105E	E	2W	11/16"	2-5/8"	1/16"	37	
11.4	11	3C110E	E	2W	11/16"	2-5/8"	1/16"	39	
12.4	12	3C120E	E	2W	11/16"	2-5/8"	1/16"	43.4	
13.4	13	3C130E	E	2A	11/16"	2-5/8"	1/16"	45	
14.4	14	3C140E	E	2A	11/16"	2-5/8"	1/16"	50	
16.4	16	3C160E	E	2A	11/16"	2-5/8"	1/16"	60	
18.4	18	3C180E	E	2A	11/16"	2-5/8"	1/16"	63	
20.4	20	3C200E	E	6A	1/16"	2-5/8"	13/16"	81	
24.4	24	3C240E	E	6A	1/16"	2-5/8"	13/16"	94.7	
27.4	27	3C270F	F	5A	13/32"	3-5/8"	5/32"	116	
30.4	30	3C300F	F	5A	13/32"	3-5/8"	5/32"	134.4	
36.4	36	3C360F	F	5A	13/32"	3-5/8"	5/32"	159	
44.4	44	3C440F	F	5A	13/32"	3-5/8"	5/32"	190	
50.4	50	3C500F	F	5A	13/32"	3-5/8"	5/32"	250	

# QD SHEAVES & BUSHINGS

## "C" Section

**Drawing Nomenclature**

B = SOLID  
W = WEB  
A = ARM (SPOKE)

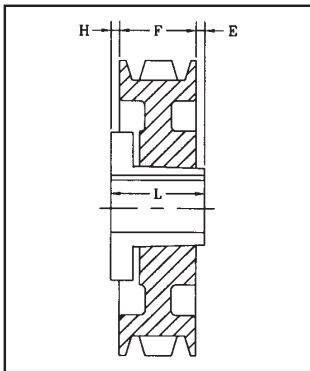

**DRAWING TYPE 5 (5A, 5B, 5W)**

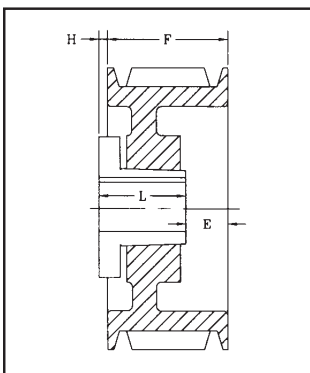

**DRAWING TYPE 6 (6A, 6W)**

Diameter Outside	"C" Datum	Four Groove	Bushing Type	Drawing	"H"	"L"	"E"	Wt. Lbs.
5.4	5	4C50SD	SD	1B	5/8"	1-13/16"	1-15/16"	10.2
5.4	5.6	4C56SD	SD	1B	7/8"	1-13/16"	1-11/16"	13
6.4	6	4C60SF	SF	1B	13/16"	2.0"	3-3/16"	15
7.4	7	4C70SF	SF	1B	3/4"	2.0"	1-5/8"	19
7.9	7.5	4C75SF	SF	1B	3/4"	2.0"	1-5/8"	22
8.4	8	4C80E	E	1B	15/16"	2-5/8"	13/16"	24
8.9	8.5	4C85E	E	2B	15/16"	2-5/8"	13/16"	28
9.4	9	4C90E	E	2B	15/16"	2-5/8"	13/16"	31
9.9	9.5	4C95E	E	2B	15/16"	2-5/8"	13/16"	34.8
10.4	10	4C100E	E	2B	15/16"	2-5/8"	13/16"	40
10.9	10.5	4C105E	E	2W	15/16"	2-5/8"	13/16"	43
11.4	11	4C110E	E	2W	15/16"	2-5/8"	13/16"	44
12.4	12	4C120E	E	2W	15/16"	2-5/8"	13/16"	50
13.4	13	4C130E	E	2A	15/16"	2-5/8"	13/16"	52
14.4	14	4C140E	E	2A	15/16"	2-5/8"	13/16"	57
15.4	15	4C150E	E	2A	15/16"	2-5/8"	13/16"	62
16.4	16	4C160E	E	2A	15/16"	2-5/8"	13/16"	67
18.4	18	4C180E	E	2A	15/16"	2-5/8"	13/16"	72
20.4	20	4C200E	E	1A	7/16"	2-5/8"	1-5/16"	86
24.4	24	4C240F	F	1A	3/32"	3-5/8"	21/32"	113
27.4	27	4C270F	F	1A	3/32"	3-5/8"	21/32"	140
30.4	30	4C300F	F	1A	3/32"	3-5/8"	21/32"	149
36.4	36	4C360F	F	1A	5/32"	3-5/8"	19/32"	185
44.4	44	4C440J	J	2A	7/32"	1-1/2"	11/32"	225
50.4	50	4C500J	J	2A	7/32"	4-1/2"	11/32"	275



**QD SHEAVE PACKAGING**  
• Individually packaged  
• Sealed in plastic wrap

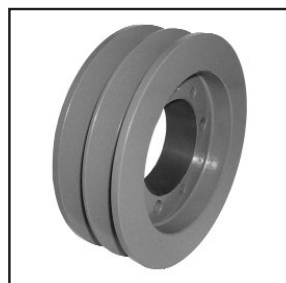

**QD "C" SHEAVE**

Standard Keyseat	
Bore Range	Keyseat
1/2"-9/16"	1/8" x 1/16"
5/8"-7/8"	3/16" x 3/32"
15/16"-1-1/4"	1/4" x 1/8"
1-5/16"-1-3/8"	5/16" x 5/32"
1-7/16"-1-3/4"	3/8" x 3/16"
1-13/16"-2-1/4"	1/2" x 1/4"
2-5/16"-2-3/4"	5/8" x 5/16"
2-13/16"-3-1/4"	3/4" x 3/8"
3-3/8"-3-3/4"	7/8" x 7/16"
3-7/8"-4-1/4"	1" x 1/2"

Diameter Outside	"C" Datum	Five Groove	Bushing Type	Drawing	"H"	"L"	"E"	Wt. Lbs.
6.4	6	5C60SF	SF	1B	1/16"	2.0"	3 5/16"	16
7.4	7	5C70SF	SF	1B	1-1/8"	2.0"	2-1/4"	23
7.9	7.5	5C75SF	SF	1B	1-1/8"	2.0"	2-1/4"	25
8.4	8	5C80E	E	1B	1-5/16"	2-5/8"	1-7/16"	28
8.9	8.5	5C85E	E	1B	1-5/16"	2-5/8"	1-7/16"	32
9.4	9	5C90E	E	1B	1-5/16"	2-5/8"	1-7/16"	36
9.9	9.5	5C95E	E	1B	1-5/16"	2-5/8"	1-7/16"	40
10.4	10	5C100E	E	1W	1-5/16"	2-5/8"	1-7/16"	41
10.9	10.5	5C105E	E	1W	1-5/16"	2-5/8"	1-7/16"	44
11.4	11	5C110E	E	1W	1-5/16"	2-5/8"	1-7/16"	47
12.4	12	5C120E	E	1W	1-5/16"	2-5/8"	1-7/16"	55
13.4	13	5C130E	E	1A	1-5/16"	2-5/8"	1-7/16"	55
14.4	14	5C140E	E	1A	1-5/16"	2-5/8"	1-7/16"	62
16.4	16	5C160E	E	1A	1-5/16"	2-5/8"	1-7/16"	73
18.4	18	5C180E	E	1A	1-5/16"	2-5/8"	1-7/16"	83
20.4	20	5C200F	F	1A	3/32"	3-5/8"	1-21/32"	109
24.4	24	5C240F	F	1A	3/32"	3-5/8"	1-21/32"	129
27.4	27	5C270F	F	1A	3/32"	3-5/8"	1-21/32"	149
30.4	30	5C300F	F	1A	3/32"	3-5/8"	1-21/32"	172
36.4	36	5C360J	J	1A	7/32"	4-1/2"	1-21/32"	205
44.4	44	5C440J	J	1A	7/32"	4-1/2"	21/32"	285
50.4	50	5C500J	J	1A	7/32"	4-1/2"	21/32"	325

**QD SHEAVES & BUSHINGS**  
**"C" Section**

Diameter Outside	"C" Datum	Six Groove	Bushing Type	Drawing	"H"	"L"	"E"	Wt. Lbs.
6.4	6	6C60SF	SF	1B	1-1/16"	2.0"	3-5/16"	24
7.4	7	6C70SF	SF	1B	1-1/8"	2.0"	3-1/4"	26
7.9	7.5	6C75SF	SF	1B	1-1/8"	2.0"	3-1/4"	29
8.4	8	6C80E	E	1B	1-5/16"	2-5/8"	2-7/16"	31
8.9	8.5	6C85E	E	1B	1-5/16"	2-5/8"	2-7/16"	35
9.4	9	6C90F	F	1B	1-7/32"	3-5/8"	1-17/32"	44
9.9	9.5	6C95F	F	1B	1-7/32"	3-5/8"	1-17/32"	49
10.4	10	6C100F	F	1B	1-7/32"	3-5/8"	1-17/32"	56
10.9	10.5	6C105F	F	1B	1-7/32"	3-5/8"	1-17/32"	56
11.4	11	6C110F	F	1W	1-7/32"	3-5/8"	1-17/32"	59
12.4	12	6C120F	F	1W	1-7/32"	3-5/8"	1-17/32"	66
13.4	13	6C130F	F	1A	1-7/32"	3-5/8"	1-17/32"	66
14.4	14	6C140F	F	1A	1-7/32"	3-5/8"	1-17/32"	75
16.4	16	6C160F	F	1A	1-7/32"	3-5/8"	1-17/32"	86
18.4	18	6C180F	F	1A	1-7/32"	3-5/8"	1-17/32"	100
20.4	20	6C200F	F	1A	2-3/32"	3-5/8"	2-1/32"	119
24.4	24	6C240F	F	1A	2-3/32"	3-5/8"	2-1/32"	141
27.4	27	6C270J	J	1A	5/32"	4-1/2"	1-23/32"	173
30.4	30	6C300J	J	1A	5/32"	4-1/2"	1-23/32"	189
36.4	36	6C360J	J	1A	7/32"	4-1/2"	1-21/32"	240
44.4	44	6C440J	J	1A	7/32"	4-1/2"	1-21/32"	290
50.4	50	6C500M	M*	2A	11/32"	6-3/4"	2-3/32"	430

- Heavy Duty Applications
- Statically Balanced and Painted
- Individually Packaged

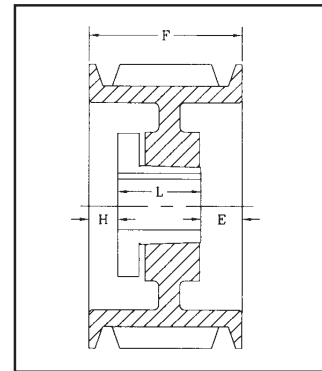

**DRAWING TYPE 1 (1A, 1B, 1W)**

Diameter Outside	"C" Datum	Seven Groove	Bushing Type	Drawing	"H"	"L"	"E"	Wt. Lbs.
7.4	7	7C70SF	SF	1B	2-3/32"	2.0"	3-9/32"	31
8.4	8	7C80E	E	1B	2-3/16"	2-5/8"	2-9/16"	34
8.9	8.5	7C85E	E	1B	2-3/16"	2-5/8"	2-9/16"	38
9.4	9	7C90F	F	1B	2-3/32"	3-5/8"	1-21/32"	45
9.9	9.5	7C95F	F	1B	2-3/32"	3-5/8"	1-21/32"	53
10.4	10	7C100F	F	1B	2-3/32"	3-5/8"	1-21/32"	58
10.9	10.5	7C105F	F	1B	2-3/32"	3-5/8"	1-21/32"	58
11.4	11	7C110F	F	1B	2-3/32"	3-5/8"	1-21/32"	73.8
12.4	12	7C120F	F	1B	2-3/32"	3-5/8"	1-21/32"	69
13.4	13	7C130F	F	1B	2-3/32"	3-5/8"	1-21/32"	82
14.4	14	7C140F	F	1W	2-3/32"	3-5/8"	1-21/32"	80
16.4	16	7C160F	F	1A	2-3/32"	3-5/8"	1-21/32"	98
18.4	18	7C180F	F	1A	2-3/32"	3-5/8"	1-21/32"	110
20.4	20	7C200J	J	1A	5/32"	4-1/2"	2-23/32"	133
24.4	24	7C240J	J	1A	5/32"	4-1/2"	2-23/32"	150
27.4	27	7C270J	J	1A	5/32"	4-1/2"	2-23/32"	175
30.4	30	7C300J	J	1A	5/32"	4-1/2"	2-23/32"	220
36.4	36	7C360J	J	1A	5/32"	4-1/2"	2-23/32"	255
44.4	44	7C440M	M*	1A	9/32"	6-3/4"	11/32"	370
50.4	50	7C500M	M*	1A	9/32"	6-3/4"	11/32"	400

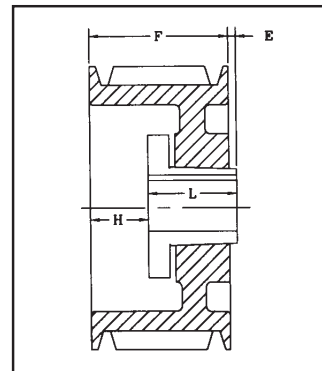

**DRAWING TYPE 2 (2A, 2B, 2W)**

Diameter Outside	"C" Datum	Eight Groove	Bushing Type	Drawing	"H"	"L"	"E"	Wt. Lbs.
7.4	7	8C70SF	SF	1B	2-13/32"	2.0"	3-31/32"	34
8.4	8	8C80E	E	1B	2-3/16"	2-5/8"	3-9/16"	38.7
8.9	8.5	8C85E	E	1B	2-3/16"	2-5/8"	3-9/16"	44
9.4	9	8C90F	F	1B	2-3/32"	3-5/8"	2-21/32"	52.7
9.9	9.5	8C95F	F	1B	2-3/32"	3-5/8"	2-21/32"	56
10.4	10	8C100F	F	1B	2-3/32"	3-5/8"	2-21/32"	62
10.9	10.5	8C105F	F	1B	2-3/32"	3-5/8"	2-21/32"	64
11.4	11	8C110F	F	1B	2-3/32"	3-5/8"	2-21/32"	80
12.4	12	8C120F	F	1B	2-3/32"	3-5/8"	2-21/32"	94
13.4	13	8C130F	F	1W	2-3/32"	3-5/8"	2-21/32"	97
14.4	14	8C140F	F	1A	2-3/32"	3-5/8"	2-21/32"	96
16.4	16	8C160F	F	1A	2-3/32"	3-5/8"	2-21/32"	111
18.4	18	8C180F	F	1A	2-3/32"	3-5/8"	2-21/32"	129
20.4	20	8C200J	J	1A	5/32"	4-1/2"	3-23/32"	158
24.4	24	8C240J	J	1A	5/32"	4-1/2"	3-23/32"	173
27.4	27	8C270J	J	1A	5/32"	4-1/2"	3-23/32"	226
30.4	30	8C300J	J	1A	5/32"	4-1/2"	3-23/32"	272
36.4	36	8C360M	M*	1A	9/32"	6-3/4"	1-11/32"	370
44.4	44	8C440M	M*	1A	9/32"	6-3/4"	1-11/32"	479
50.4	50	8C500M	M*	1A	9/32"	6-3/4"	1-11/32"	570

\* M-N-P bushings are standard mounting only.

# QD SHEAVES & BUSHINGS

## "D" Section



QD "D" SHEAVE



QD SHEAVE PACKAGING

- Individually packaged
- Sealed in plastic wrap

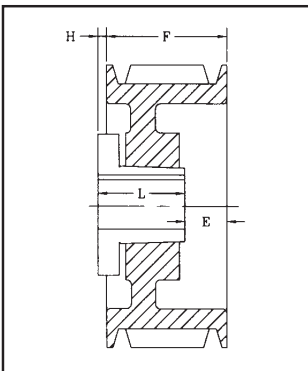

DRAWING  
TYPE 6  
(6A)

\* M-N-P bushings are standard mounting only.

Diameter Outside	"D" Datum	Three Groove	Bushing Type	Drawing	"H"	"L"	"E"	Wt. Lbs.
12	12.6	3D120F	F	1W	9/32"	3-5/8"	23/32"	58
13	13.6	3D130F	F	1W	9/32"	3-5/8"	23/32"	62
13.5	14.1	3D135F	F	1W	9/32"	3-5/8"	23/32"	65
14	14.6	3D140F	F	1W	9/32"	3-5/8"	23/32"	71
14.5	15.1	3D145F	F	1W	9/32"	3-5/8"	23/32"	75
15	15.6	3D150F	F	1W	9/32"	3-5/8"	23/32"	79
15.5	16.1	3D155F	F	1W	9/32"	3-5/8"	23/32"	90
16	16.6	3D160F	F	1W	9/32"	3-5/8"	23/32"	95
18	18.6	3D180J	J	6A	7/32"	4-1/2"	11/32"	115
22	22.6	3D220J	J	6A	7/32"	4-1/2"	11/32"	135
27	27.6	3D270J	J	6A	7/32"	4-1/2"	11/32"	170
33	33.6	3D330J	J	6A	7/32"	4-1/2"	11/32"	215
40	40.6	3D400J	J	6A	7/32"	4-1/2"	11/32"	275

Diameter Outside	"D" Datum	Four Groove	Bushing Type	Drawing	"H"	"L"	"E"	Wt. Lbs.
12	12.6	4D120F	F	1W	1-3/32"	3-5/8"	1-11/32"	70
13	13.6	4D130F	F	1W	1-3/32"	3-5/8"	1-11/32"	74
13.5	14.1	4D135F	F	1W	1-3/32"	3-5/8"	1-11/32"	78
14	14.6	4D140F	F	1W	1-3/32"	3-5/8"	1-11/32"	83
14.5	15.1	4D145F	F	1W	1-3/32"	3-5/8"	1-11/32"	87
15	15.6	4D150F	F	1W	1-3/32"	3-5/8"	1-11/32"	94
15.5	16.1	4D155F	F	1W	1-3/32"	3-5/8"	1-11/32"	102
16	16.6	4D160F	F	1W	1-3/32"	3-5/8"	1-11/32"	110
17	17.6	4D170J	J	1A	1-5/32"	4-1/2"	13/32"	127
18	18.6	4D180J	J	1A	1-5/32"	4-1/2"	13/32"	131
20	20.6	4D200J	J	1A	1-5/32"	4-1/2"	13/32"	145
22	22.6	4D220J	J	1A	5/32"	4-1/2"	1-13/32"	160
27	27.6	4D270J	J	1A	5/32"	4-1/2"	1-13/32"	200
33	33.6	4D330M	M*	2A	9/32"	6-3/4"	31/32"	285
40	40.6	4D400M	M*	2A	9/32"	6-3/4"	31/32"	375

Diameter Outside	"D" Datum	Five Groove	Bushing Type	Drawing	"H"	"L"	"E"	Wt. Lbs.
12	12.6	5D120F	F	1W	1-27/32"	3-5/8"	2-1/32"	71
13	13.6	5D130F	F	1W	1-27/32"	3-5/8"	2-1/32"	81
13.5	14.1	5D135F	F	1W	1-27/32"	3-5/8"	2-1/32"	92
14	14.6	5D140F	F	1W	1-27/32"	3-5/8"	2-1/32"	90
14.5	15.1	5D145F	F	1W	1-27/32"	3-5/8"	2-1/32"	100
15	15.6	5D150F	F	1W	1-27/32"	3-5/8"	2-1/32"	102
15.5	16.1	5D155F	F	1W	1-27/32"	3-5/8"	2-1/32"	111
16	16.6	5D160F	F	1A	1-27/32"	3-5/8"	2-1/32"	110
17	17.6	5D170J	J	1A	1-29/32"	4-1/2"	1-3/32"	148
18	18.6	5D180J	J	1A	1-29/32"	4-1/2"	1-3/32"	131
20	20.6	5D200J	J	1A	5/32"	4-1/2"	2-27/32"	148
22	22.6	5D220J	J	1A	5/32"	4-1/2"	2-27/32"	152
27	27.6	5D270M	M*	1A	9/32"	6-3/4"	15/32"	250
33	33.6	5D330M	M*	1A	9/32"	6-3/4"	15/32"	321
40	40.6	5D400M	M*	1A	9/32"	6-3/4"	15/32"	424
48	48.6	5D480M	M*	1A	9/32"	6-3/4"	15/32"	550
58	58.6	5D580M	M*	1A	9/32"	6-3/4"	15/32"	600

Diameter Outside	"D" Datum	Six Groove	Bushing Type	Drawing	"H"	"L"	"E"	Wt. Lbs.
12	12.6	6D120J	J	1B	1-29/32"	4-1/2"	2-17/32"	87
13	13.6	6D130J	J	1B	1-29/32"	4-1/2"	2-17/32"	97
13.5	14.1	6D135J	J	1B	1-29/32"	4-1/2"	2-17/32"	110
14	14.6	6D140J	J	1B	1-29/32"	4-1/2"	2-17/32"	115
14.5	15.1	6D145J	J	1B	1-29/32"	4-1/2"	2-17/32"	117
15	15.6	6D150J	J	1W	1-29/32"	4-1/2"	2-17/32"	130
15.5	16.1	6D155J	J	1W	1-29/32"	4-1/2"	2-17/32"	131
16	16.6	6D160J	J	1A	1-29/32"	4-1/2"	2-17/32"	137
17	17.6	6D170J	J	1A	1-29/32"	4-1/2"	2-17/32"	175
18	18.6	6D180J	J	1A	1-29/32"	4-1/2"	2-17/32"	159
20	20.6	6D200J	J	1A	1-29/32"	4-1/2"	2-17/32"	185
22	22.6	6D220M	M*	1A	9/32"	6-3/4"	1-29/32"	225
27	27.6	6D270M	M*	1A	9/32"	6-3/4"	1-29/32"	300
33	33.6	6D330M	M*	1A	9/32"	6-3/4"	1-29/32"	350
40	40.6	6D400M	M*	1A	9/32"	6-3/4"	1-29/32"	460
48	48.6	6D480M	M*	1A	9/32"	6-3/4"	1-29/32"	600
58	58.6	6D580N	N*	1A	9/32"	6-3/4"	1-29/32"	760



**QD SHEAVES & BUSHINGS**  
**"D" Section**

7-GROOVE ("F" DIMENSION = 10-3/8")	Diameter Outside	"D" Datum	Seven Groove	Bushing Type	Drawing	"H"	"L"	"E"	Wt. Lbs.
	12	12.6	7D120J	J	1B	2-5/32"	4-1/2"	3-23/32"	111
	13	13.6	7D130J	J	1B	2-5/32"	4-1/2"	3-23/32"	116
	13.5	14.1	7D135J	J	1B	2-5/32"	4-1/2"	3-23/32"	121
	14	14.6	7D140J	J	1W	2-5/32"	4-1/2"	3-23/32"	126
	14.5	15.1	7D145J	J	1W	2-5/32"	4-1/2"	3-23/32"	132
	15	15.6	7D150J	J	1W	2-5/32"	4-1/2"	3-23/32"	139
	15.5	16.1	7D155J	J	1W	2-5/32"	4-1/2"	3-23/32"	150
	16	16.6	7D160J	J	1W	2-5/32"	4-1/2"	3-23/32"	160
	17	17.6	7D170J	J	1W	2-5/32"	4-1/2"	3-23/32"	197
18	18.6	7D180M	M*	1A	27/32"	6-3/4"	2-25/32"	180	
20	20.6	7D200M	M*	1A	27/32"	6-3/4"	2-25/32"	225	
22	22.6	7D220M	M*	1A	9/32"	6-3/4"	3-11/32"	250	
27	27.6	7D270M	M*	1A	9/32"	6-3/4"	3-11/32"	305	
33	33.6	7D330M	M*	1A	9/32"	6-3/4"	3-11/32"	410	
40	40.6	7D400M	M*	1A	1/8"	6-3/4"	2-1/8"	525	
48	48.6	7D480M	M*	1A	1/8"	8-1/8"	2-1/8"	725	
58	58.6	7D580M	M*	1A	1/8"	8-1/8"	2-1/8"	890	

- Heavy Duty Applications
- Statically Balanced and Painted
- Individually Packaged

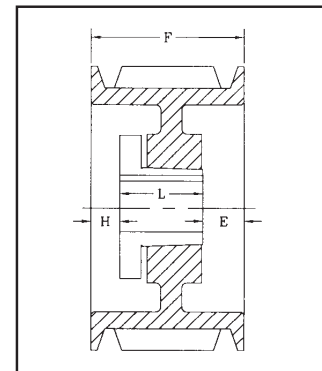

**DRAWING TYPE 1 (1A, 1B, 1W)**

\* 7-Groove Sheave pricing available on request.

8-GROOVE ("F" DIMENSION = 11-13/16")	Diameter Outside	"D" Datum	Eight Groove	Bushing Type	Drawing	"H"	"L"	"E"	Wt. Lbs.
	12	12.6	8D120J	J	1B	2-5/32"	4-1/2"	5-5/32"	108
	13	13.6	8D130J	J	1B	2-5/32"	4-1/2"	5-5/32"	114
	13.5	14.1	8D135J	J	1B	2-5/32"	4-1/2"	5-5/32"	116
	14	14.6	8D140J	J	1B	2-5/32"	4-1/2"	5-5/32"	135
	14.5	15.1	8D145J	J	1B	2-5/32"	4-1/2"	5-5/32"	141
	15	15.6	8D150J	J	1W	2-5/32"	4-1/2"	5-5/32"	148
	15.5	16.1	8D155J	J	1W	2-5/32"	4-1/2"	5-5/32"	151
	16	16.6	8D160J	J	1W	2-5/32"	4-1/2"	5-5/32"	165
	17	17.6	8D170J	J	1W	2-5/32"	4-1/2"	5-5/32"	215
18	18.6	8D180M	M*	1W	2-9/32"	6-3/4"	2-25/32"	224	
20	20.6	8D200M	M*	1A	2-9/32"	6-3/4"	2-25/32"	258	
22	22.6	8D220M	M*	1A	9/32"	6-3/4"	4-25/32"	266	
27	27.6	8D270M	M*	1A	9/32"	6-3/4"	4-25/32"	320	
33	33.6	8D330M	M*	1A	9/32"	6-3/4"	4-25/32"	420	
40	40.6	8D400N	N*	1A	1/8"	8-1/8"	3-9/16"	600	
48	48.6	8D480N	N*	1A	1/8"	8-1/8"	3-9/16"	750	
58	58.6	8D580N	N*	1A	1/8"	8-1/8"	3-9/16"	1000	

\* M-N-P bushings are standard mounting only.

9-GROOVE ("F" DIMENSION = 13-1/4")	Diameter Outside	"D" Datum	Nine Groove	Bushing Type	Drawing	"H"	"L"	"E"	Wt. Lbs.
	12	12.6	9D120M	M*	1B	2-9/32"	6-3/4"	4-7/32"	154
	13	13.6	9D130M	M*	1B	2-9/32"	6-3/4"	4-7/32"	180
	13.5	14.1	9D135M	M*	1B	2-9/32"	6-3/4"	4-7/32"	195
	14	14.6	9D140M	M*	1B	2-9/32"	6-3/4"	4-7/32"	203
	14.5	15.1	9D145M	M*	1B	2-9/32"	6-3/4"	4-7/32"	211
	15	15.6	9D150M	M*	1B	2-9/32"	6-3/4"	4-7/32"	220
	15.5	16.1	9D155M	M*	1B	2-9/32"	6-3/4"	4-7/32"	232
	16	16.6	9D160M	M*	1B	2-9/32"	6-3/4"	4-7/32"	245
	17	17.6	9D170M	M*	1W	2-9/32"	6-3/4"	4-7/32"	265
18	18.6	9D180M	M*	1W	2-9/32"	6-3/4"	4-7/32"	275	
22	22.6	9D220M	M*	1A	1-9/32"	6-3/4"	5-7/32"	310	
27	27.6	9D270M	M*	1A	1-9/32"	6-3/4"	5-7/32"	375	
33	33.6	9D330N	N*	1A	1/8"	8-1/8"	5"	525	
40	40.6	9D400N	N*	1A	1/8"	8-1/8"	5"	675	
48	48.6	9D480P	P*	1A	3/16"	8-1/8"	3-11/16"	840	
58	58.6	9D580P	P*	1A	3/16"	9-3/8"	3-11/16"	1200	

\* 9-Groove Sheave pricing available on request.

**Drawing Nomenclature**  
**B = SOLID**  
**W = WEB**  
**A = ARM (SPOKE)**

## QD SHEAVES & BUSHINGS "D" Section

Standard Keyseat	
Bore Range	Keyseat
1/2"-9/16"	1/8" x 1/16"
5/8"-7/8"	3/16" x 3/32"
15/16"-1-1/4"	1/4" x 1/8"
1-5/16"-1-3/8"	5/16" x 5/32"
1-7/16"-1-3/4"	3/8" x 3/16"
1-13/16"-2-1/4"	1/2" x 1/4"
2-5/16"-2-3/4"	5/8" x 5/16"
2-13/16"-3-1/4"	3/4" x 3/8"
3-3/8"-3-3/4"	7/8" x 7/16"
3-7/8"-4-1/4"	1" x 1/2"

\* M-N-P bushings are standard mounting only.

10-GROOVE ("F" DIMENSION = 14-11/16")	Diameter Outside	"D" Datum	Ten Groove Groove	Bushing Type	Drawing	"H"	"L"	"E"	Wt. Lbs.
	12	12.6	10D120M	M*	1B	2-9/32"	6-3/4"	5-21/32"	155
13	13.6	10D130M	M*	1B	2-9/32"	6-3/4"	5-21/32"	190	
13.5	14.1	10D135M	M*	1B	2-9/32"	6-3/4"	5-21/32"	215	
14	14.6	10D140M	M*	1B	2-9/32"	6-3/4"	5-21/32"	218	
14.5	15.1	10D145M	M*	1B	2-9/32"	6-3/4"	5-21/32"	225	
15	15.6	10D150M	M*	1B	2-9/32"	6-3/4"	5-21/32"	210	
15.5	16.1	10D155M	M*	1B	2-9/32"	6-3/4"	5-21/32"	216	
16	16.6	10D160M	M*	1B	2-9/32"	6-3/4"	5-21/32"	222	
17	17.6	10D170M	M*	1B	2-9/32"	6-3/4"	5-21/32"	350	
18	18.6	10D180M	M*	1W	2-9/32"	6-3/4"	5-21/32"	275	
20	20.6	10D200M	M*	1A	2-9/32"	6-3/4"	5-21/32"	315	
22	22.6	10D220M	M*	1A	1-9/32"	6-3/4"	6-21/32"	342	
27	27.6	10D270M	M*	1A	1-9/32"	6-3/4"	6-21/32"	415	
33	33.6	10D330N	N*	1A	1-11/32"	8-1/8"	5-7/32"	575	
40	40.6	10D400N	N*	1A	1-11/32"	8-1/8"	5-7/32"	580	
48	48.6	10D480P	P*	1A	3/16"	9-3/8"	5-1/8"	975	
58	58.6	10D580P	P*	1A	3/16"	9-3/8"	5-1/8"	1250	

- Heavy Duty Applications
- Statically Balanced and Painted
- Individually Packaged

## QD SHEAVES & BUSHINGS "3V" Section

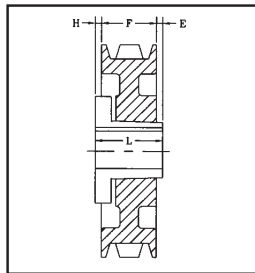

**DRAWING TYPE 5 - (5A)**



**QD "3V" SHEAVE**



**QD SHEAVE PACKAGING**

- Individually packaged
- Sealed in plastic wrap

Standard Keyseat	
Bore Range	Keyseat
1/2"-9/16"	1/8" x 1/16"
5/8"-7/8"	3/16" x 3/32"
15/16"-1-1/4"	1/4" x 1/8"
1-5/16"-1-3/8"	5/16" x 5/32"
1-7/16"-1-3/4"	3/8" x 3/16"
1-13/16"-2-1/4"	1/2" x 1/4"
2-5/16"-2-3/4"	5/8" x 5/16"
2-13/16"-3-1/4"	3/4" x 3/8"
3-3/8"-3-3/4"	7/8" x 7/16"
3-7/8"-4-1/4"	1" x 1/2"

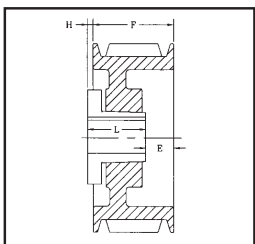

**DRAWING TYPE 6 - (6A, 6B, 6W)**

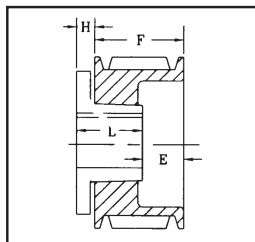

**DRAWING TYPE 11 - (11B)**

1-GROOVE ("F" DIMENSION = 11 1/16" up to 10.60 O.D. incl. and 13/16" thereafter)	Diameter Outside	One Groove	Bushing Type	Drawing	"H"	"L"	"E"	Wt. Lbs.
	2.2	1/3V220JA	JA	11B	33/64"	1"	45/64"	0.8
2.35	1/3V235JA	JA	11B	33/64"	1"	45/64"	0.85	
2.5	1/3V250JA	JA	11B	33/64"	1"	45/64"	0.92	
2.65	1/3V265JA	JA	6B	26/64"	1"	9/64"	0.5	
2.8	1/3V280JA	JA	6B	26/64"	1"	9/64"	0.7	
3	1/3V300JA	JA	6B	26/64"	1"	9/64"	0.7	
3.15	1/3V315JA	JA	6B	26/64"	1"	9/64"	0.7	
3.35	1/3V335JA	JA	6B	26/64"	1"	9/64"	1.1	
3.65	1/3V365SH	SH	6B	5/8"	1-1/4"	1/16"	1.3	
4.12	1/3V412SH	SH	6B	5/8"	1-1/4"	1/16"	1.8	
4.5	1/3V450SH	SH	6B	5/8"	1-1/4"	1/16"	2.2	
4.75	1/3V475SH	SH	6B	5/8"	1-1/4"	1/16"	2.2	
5	1/3V500SH	SH	6B	5/8"	1-1/4"	1/16"	2.9	
5.3	1/3V530SH	SH	6B	5/8"	1-1/4"	1/16"	3.3	
5.6	1/3V560SH	SH	6B	5/8"	1-1/4"	1/16"	3.7	
6	1/3V600SH	SH	6W	5/8"	1-1/4"	1/16"	3.9	
6.5	1/3V650SH	SH	6W	5/8"	1-1/4"	1/16"	4.9	
6.9	1/3V690SH	SH	6W	5/8"	1-1/4"	1/16"	5.5	
8	1/3V800SDS	SDS	6A	11/16"	1-5/16"	1/16"	5.1	
10.6	1/3V1060SDS	SDS	6A	11/16"	1-5/16"	1/16"	8.6	
14	1/3V1400SK	SK	5A	13/16"	1-7/8"	1/4"	15.3	
19	1/3V1900SK	SK	5A	29/32"	1-7/8"	5/32"	18.3	

**QD SHEAVES & BUSHINGS**  
**"3V" Section**

Diameter Outside	Two Groove	Bushing Type	Drawing	"H"	"L"	"E"	Wt. Lbs.
2.2	2/3V220JA	JA	11B	33/64"	1"	1-7/64"	0.9
2.35	2/3V235JA	JA	11B	33/64"	1"	1-7/64"	1
2.5	2/3V250JA	JA	11B	33/64"	1"	1-7/64"	1.1
2.65	2/3V265JA	JA	6B	25/64"	1"	31/64"	0.8
2.8	2/3V280JA	JA	6B	25/64"	1"	31/64"	1
3	2/3V300JA	JA	6B	25/64"	1"	31/64"	1.2
3.15	2/3V315JA	JA	6B	25/64"	1"	31/64"	1.4
3.35	2/3V335SH	SH	6B	1/2"	1-1/4"	11/32"	1.2
3.65	2/3V365SH	SH	6B	1/2"	1-1/4"	11/32"	1.6
4.12	2/3V412SH	SH	6B	9/32"	1-1/4"	1/8"	2.2
4.5	2/3V450SH	SH	6B	9/32"	1-1/4"	1/8"	2.7
4.75	2/3V475SH	SH	6B	9/32"	1-1/4"	1/8"	3.2
5	2/3V500SH	SH	6B	9/32"	1-1/4"	1/8"	3.7
5.3	2/3V530SH	SH	6B	9/32"	1-1/4"	1/8"	4.2
5.6	2/3V560SH	SH	6B	9/32"	1-1/4"	1/8"	4.6
6	2/3V600SH	SH	6W	9/32"	1-1/4"	1/8"	5
6.5	2/3V650SDS	SDS	6W	3/8"	1-5/16"	5/32"	5.8
6.9	2/3V690SDS	SDS	6W	3/8"	1-5/16"	5/32"	6.4
8	2/3V800SDS	SDS	6A	3/8"	1-5/16"	5/32"	6.6
10.6	2/3V1060SK	SK	5A	5/8"	1-7/8"	5/32"	11.7
14	2/3V1400SK	SK	5A	5/8"	1-7/8"	5/32"	17.9
19	2/3V1900SK	SK	5A	13/16"	1-7/8"	1/32"	26.6
25	2/3V2500SF	SF	5A	13/16"	2"	3/32"	33.4

- Heavy Duty Applications
- Statically Balanced and Painted
- Individually Packaged

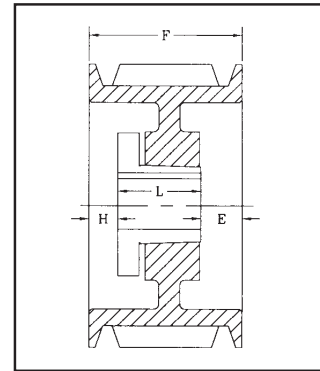

**DRAWING TYPE 1 (1A, 1B, 1W)**

Diameter Outside	Three Groove	Bushing Type	Drawing	"H"	"L"	"E"	Wt. Lbs.
2.5	3/3V250JA	JA	11B	33/64"	1"	7/8"	1.1
2.65	3/3V265JA	JA	6B	3/8"	1"	7/8"	1.1
2.8	3/3V280JA	JA	6B	3/8"	1"	7/8"	1.3
3	3/3V300SH	SH	11B	5/8"	1-1/4"	1-1/4"	1.6
3.15	3/3V315SH	SH	11B	5/8"	1-1/4"	1-1/4"	2
3.35	3/3V335SH	SH	6B	9/16"	1-1/4"	13/16"	1.8
3.65	3/3V365SH	SH	6B	9/16"	1-1/4"	13/16"	2.4
4.12	3/3V412SH	SH	1B	0	1-5/16"	3/16"	2.7
4.5	3/3V450SDS	SDS	1B	0	1-5/16"	3/16"	3
4.75	3/3V475SDS	SDS	1B	0	1-5/16"	3/16"	3.7
5	3/3V500SDS	SDS	1B	0	1-5/16"	3/16"	4.2
5.3	3/3V530SDS	SDS	1B	0	1-5/16"	3/16"	4.7
5.6	3/3V560SDS	SDS	1B	0	1-5/16"	3/16"	5.2
6	3/3V600SDS	SDS	1B	0	1-5/16"	3/16"	5.2
6.5	3/3V650SDS	SDS	1W	0	1-5/16"	3/16"	5.7
6.9	3/3V690SDS	SDS	1W	0	1-5/16"	3/16"	7.5
8	3/3V800SK	SK	6A	5/8"	1-7/8"	1/4"	9.8
10.6	3/3V1060SK	SK	6A	5/8"	1-7/8"	1/4"	14
14	3/3V1400SK	SK	6A	5/8"	1-7/8"	1/4"	19.4
19	3/3V1900SF	SF	6A	13/16"	2"	5/16"	32.1
25	3/3V2500SF	SF	6A	13/16"	2"	5/16"	38.5
33.5	3/3V3350SF	SF	6A	23/32"	2"	7/32"	79.3

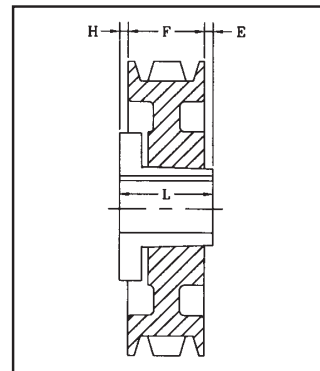

**DRAWING TYPE 5 (5A)**

Diameter Outside	Four Groove	Bushing Type	Drawing	"H"	"L"	"E"	Wt. Lbs.
2.65	4/3V265JA	JA	6B	3/8"	1"	1-9/32"	1.4
2.8	4/3V280JA	JA	6B	3/8"	1"	1-9/32"	1.6
3	4/3V300SH	SH	11B	5/8"	1-1/4"	1-21/32"	2.3
3.15	4/3V315SH	SH	11B	5/8"	1-1/4"	1-21/32"	2.7
3.35	4/3V335SH	SH	6B	1/2"	1-1/4"	1-5/32"	2.3
3.65	4/3V365SH	SH	6B	1/2"	1-1/4"	1-5/32"	3.1
4.12	4/3V412SH	SH	1B	5/16"	1-1/4"	11/32"	3.2
4.5	4/3V450SDS	SDS	1B	1/8"	1-5/16"	15/32"	3.4
4.75	4/3V475SDS	SDS	1B	1/8"	1-5/16"	15/32"	4.4
5	4/3V500SDS	SDS	1B	1/8"	1-5/16"	15/32"	5
5.3	4/3V530SDS	SDS	1B	1/4"	1-5/16"	11/32"	6
5.6	4/3V560SDS	SDS	1B	1/8"	1-5/16"	15/32"	6.2
6	4/3V600SK	SK	6B	1/4"	1-7/8"	9/32"	7.8
6.5	4/3V650SK	SK	6B	1/4"	1-7/8"	9/32"	9.5
6.9	4/3V690SK	SK	6B	1/4"	1-7/8"	9/32"	11.1
8	4/3V800SK	SK	6A	1/4"	1-7/8"	9/32"	11.2
10.6	4/3V1060SK	SK	6A	1/4"	1-7/8"	9/32"	16
14	4/3V1400SK	SK	6A	1/4"	1-7/8"	9/32"	25
19	4/3V1900SF	SF	6A	7/16"	2"	11/32"	39.8
25	4/3V2500SF	SF	6A	7/16"	2"	11/32"	51.1
33.5	4/3V3350E	E	6A	25/32"	2-5/8"	1/16"	94.1

# OD SHEAVES & BUSHINGS "3V" Section

**Drawing Nomenclature**

**B = SOLID**  
**W = WEB**  
**A = ARM (SPOKE)**

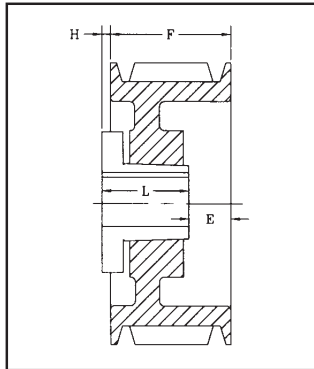

**DRAWING TYPE 6 (6A, 6B, 6W)**

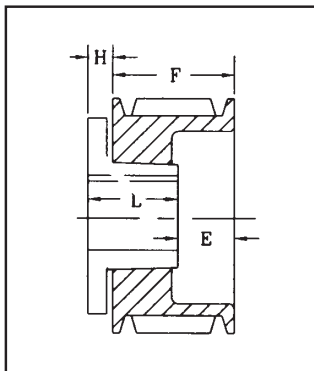

**DRAWING TYPE 11 (11B)**

**5-GROOVE ("F" DIMENSION = 2-5/16")**

Diameter Outside	Five Groove	Bushing Type	Drawing	"H"	"L"	"E"	Wt. Lbs.
4.75	5/3V475SDS	SDS	1B	1/8"	1-5/16"	7/8"	4.7
5	5/3V500SDS	SDS	1B	1/8"	1-5/16"	7/8"	6
5.3	5/3V530SK	SK	1B	1/16"	1-7/8"	3/8"	6.2
5.6	5/3V560SK	SK	1B	1/32"	1-7/8"	13/32"	7.4
6	5/3V600SK	SK	1B	1/16"	1-7/8"	3/8"	8.8
6.5	5/3V650SK	SK	1B	1/16"	1-7/8"	3/8"	9.9
6.9	5/3V690SK	SK	1B	1/32"	1-7/8"	13/32"	11.5
8	5/3V800SK	SK	1W	1/16"	1-7/8"	3/8"	14.5
10.6	5/3V1060SK	SK	1A	5/32"	1-7/8"	9/32"	19.3
14	5/3V1400SF	SF	6A	3/32"	2"	13/32"	26.5
19	5/3V1900SF	SF	1A	3/32"	2"	7/32"	33.9
25	5/3V2500E	E	6A	7/16"	2-5/8"	1/8"	60.7
33.5	5/3V3350E	E	6A	3/8"	2-5/8"	1/16"	107

**6-GROOVE ("F" DIMENSION = 2-23/32")**

Diameter Outside	Six Groove	Bushing Type	Drawing	"H"	"L"	"E"	Wt. Lbs.
4.75	6/3V475SK	SK	11B	13/16"	1-7/8"	1-21/32"	5.8
5	6/3V500SK	SK	11B	13/16"	1-7/8"	1-21/32"	7.1
5.3	6/3V530SK	SK	1B	15/32"	1-7/8"	3/8"	6.8
5.6	6/3V560SK	SK	1B	7/16"	1-7/8"	13/32"	8.2
6	6/3V600SK	SK	1B	7/16"	1-7/8"	13/32"	9.7
6.5	6/3V650SK	SK	1B	1/16"	1-7/8"	25/32"	10.8
6.9	6/3V690SK	SK	1B	7/16"	1-7/8"	13/32"	12.2
8	6/3V800SK	SK	1W	1/16"	1-7/8"	25/32"	16
10.6	6/3V1060SF	SF	1A	5/32"	2"	9/16"	18.7
14	6/3V1400SF	SF	1A	3/32"	2"	5/8"	30.5
19	6/3V1900E	E	6A	1/32"	2-5/8"	1/8"	47.6
25	6/3V2500E	E	6A	1/32"	2-5/8"	1/8"	66.9
33.5	6/3V3350E	E	1A	1/32"	2-5/8"	1/16"	121.6

**8-GROOVE ("F" DIMENSION = 2-23/32")**

Diameter Outside	Eight Groove	Bushing Type	Drawing	"H"	"L"	"E"	Wt. Lbs.
4.75	8/3V475SK	SK	11B	13/16"	1-7/8"	15/32"	7.2
5	8/3V500SK	SK	11B	13/16"	1-7/8"	15/32"	8.9
5.3	8/3V530SK	SK	1B	7/16"	1-7/8"	1-7/32"	8.3
5.6	8/3V560SK	SK	1B	7/16"	1-7/8"	1-7/32"	9.6
6	8/3V600SK	SK	1B	7/16"	1-7/8"	1-7/32"	11.7
6.5	8/3V650SK	SK	1B	7/16"	1-7/8"	1-7/32"	13.6
6.9	8/3V690SK	SK	1B	7/16"	1-7/8"	1-7/32"	15.4
8	8/3V800SF	SF	1W	5/16"	2"	1-7/32"	19.2
10.6	8/3V1060SF	SF	1A	5/16"	2"	1-7/32"	22.5
14	8/3V1400E	E	6A	1/8"	2-5/8"	1-1/32"	42.9
19	8/3V1900E	E	6A	1/8"	2-5/8"	1-1/32"	66.6
25	8/3V2500E	E	6A	3/16"	2-5/8"	1-3/32"	92.2
33.5	8/3V3350E	F	6A	15/32"	3-5/8"	3/8"	153

**10-GROOVE ("F" DIMENSION = 4-11/32")**

Diameter Outside	Ten Groove	Bushing Type	Drawing	"H"	"L"	"E"	Wt. Lbs.
4.75	10/3V475SK	SK	11B	13/16"	1-7/8"	3-9/32"	8.6
5	10/3V500SK	SK	11B	13/16"	1-7/8"	3-9/32"	10.7
5.3	10/3V530SK	SK	1B	9/16"	1-7/8"	1-29/32"	9.6
5.6	10/3V560SK	SK	1B	9/16"	1-7/8"	1-29/32"	11.9
6	10/3V600SK	SK	1B	9/16"	1-7/8"	1-29/32"	13.45
6.5	10/3V650SK	SK	1B	9/16"	1-7/8"	1-29/32"	14.1
6.9	10/3V690SK	SK	1B	9/16"	1-7/8"	1-29/32"	17.5
8	10/3V800SF	SF	1W	11/16"	2"	1-21/32"	21.55
10.6	10/3V1060E	E	1W	0	2-5/8"	1-23/32"	31.6
14	10/3V1400E	E	1A	0	2-5/8"	1-23/32"	41.6
19	10/3V1900E	E	1A	0	2-5/8"	1-23/32"	74
25	10/3V2500F	F	1A	1/16"	3-5/8"	25/32"	105
33.5	10/3V3350F	F	1A	1/16"	3-5/8"	25/32"	180

- Heavy Duty Applications
- Statically Balanced and Painted
- Individually Packaged

**QD SHEAVES & BUSHINGS**  
**"5V" Section**

2-GROOVE ("F" DIMENSION = 1-11/16")	Diameter Outside	Two Groove	Bushing Type	Drawing	"H"	"L"	"E"	Wt. Lbs.
	4.4	2/5V440SH	SH	6B	1/2"	1-1/4"	15/16"	5.8
	4.65	2/5V465SDS	SDS	11B	11/16"	1-5/16"	1-1/16"	6.6
	4.9	2/5V490SDS	SDS	6B	7/32"	1-5/16"	3/8"	6.8
	5.2	2/5V520SDS	SDS	6B	7/32"	1-5/16"	19/32"	7
	5.5	2/5V550SDS	SDS	6B	7/32"	1-5/16"	19/32"	7.2
	5.9	2/5V590SDS	SDS	6B	7/32"	1-5/16"	19/32"	7.6
	6.3	2/5V630SK	SK	6B	7/16"	1-7/8"	1/4"	9.4
	6.7	2/5V670SK	SK	6B	7/16"	1-7/8"	1/4"	10.5
	7.1	2/5V710SK	SK	6B	3/8"	1-7/8"	3/16"	11.5
7.5	2/5V750SK	SK	6B	3/8"	1-7/8"	3/16"	12.5	
8	2/5V800SK	SK	6B	3/8"	1-7/8"	3/16"	13	
8.5	2/5V850SK	SK	6B	3/8"	1-7/8"	3/16"	14	
9	2/5V900SK	SK	6B	3/8"	1-7/8"	3/16"	15.2	
9.25	2/5V925SK	SK	6W	3/8"	1-7/8"	3/16"	15.3	
9.75	2/5V975SK	SK	6W	3/8"	1-7/8"	3/16"	15.5	
10.3	2/5V1030SK	SK	6W	3/8"	1-7/8"	3/16"	15.5	
10.9	2/5V1090SK	SK	6W	3/8"	1-7/8"	3/16"	16.5	
11.3	2/5V1130SK	SK	6A	3/8"	1-7/8"	3/16"	17.8	
11.8	2/5V1180SK	SK	6A	3/8"	1-7/8"	3/16"	19	
12.5	2/5V1250SF	SF	5A	3/8"	2"	1/16"	21	
13.2	2/5V1320SF	SF	5A	3/8"	2"	1/16"	22.6	
14	2/5V1400SF	SF	5A	3/8"	2"	1/16"	25.3	
15	2/5V1500SF	SF	5A	3/8"	2"	1/16"	27.4	
16	2/5V1600SF	SF	5A	3/8"	2"	1/16"	29.2	
18.7	2/5V1870SF	SF	5A	3/8"	2"	1/16"	36	
21.2	2/5V2120SF	SF	5A	3/8"	2"	1/16"	43	
23.6	2/5V2360E	E	5A	5/16"	2-5/8"	5/8"	55	
28	2/5V2800E	E	5A	5/16"	2-5/8"	5/8"	67	



**QD "5V" SHEAVE**



**QD SHEAVE PACKAGING**

- Individually packaged
- Sealed in plastic wrap

3-GROOVE ("F" DIMENSION = 2-3/8")	Diameter Outside	Three Groove	Bushing Type	Drawing	"H"	"L"	"E"	Wt. Lbs.
	4.4	3/5V440SDS	SDS	11B	11/16"	1-5/16"	1-3/4"	4.3
	4.65	3/5V465SDS	SDS	11B	11/16"	1-5/16"	1-3/4"	5.2
	4.9	3/5V490SDS	SDS	1B	3/8"	1-5/16"	11/18"	4.9
	5.2	3/5V520SDS	SDS	1B	3/8"	1-5/16"	11/18"	6.1
	5.5	3/5V550SDS	SDS	1B	5/16"	1-5/16"	3/4"	6.4
	5.9	3/5V590SDS	SDS	1B	5/16"	1-5/16"	3/4"	8.2
	6.3	3/5V630SK	SK	1B	1/4"	1-7/8"	1/4"	9
	6.7	3/5V670SK	SK	1B	1/4"	1-7/8"	1/4"	12.7
	7.1	3/5V710SF	SF	6B	1/16"	2"	7/16"	12.3
7.5	3/5V750SF	SF	6B	1/16"	2"	7/16"	13.8	
8	3/5V800SF	SF	6B	1/16"	2"	7/16"	16.2	
8.5	3/5V850SF	SF	6B	1/16"	2"	7/16"	18.3	
9	3/5V900SF	SF	6B	1/16"	2"	7/16"	20.6	
9.25	3/5V925SF	SF	6W	1/16"	2"	7/16"	20.2	
9.75	3/5V975SF	SF	6W	1/16"	2"	7/16"	20.8	
10.3	3/5V1030SF	SF	6W	1/16"	2"	7/16"	20.5	
10.9	3/5V1090SF	SF	6W	1/16"	2"	7/16"	23.4	
11.3	3/5V1130SF	SF	6A	1/16"	2"	7/16"	22.7	
11.8	3/5V1180SF	SF	6A	1/16"	2"	7/16"	24.4	
12.5	3/5V1250E	E	6A	11/16"	2-5/8"	7/16"	31.1	
13.2	3/5V1320E	E	6A	11/16"	2-5/8"	7/16"	32.2	
14	3/5V1400E	E	6A	11/16"	2-5/8"	7/16"	35.5	
15	3/5V1500E	E	6A	11/16"	2-5/8"	7/16"	38.3	
16	3/5V1600E	E	6A	11/16"	2-5/8"	7/16"	40.1	
18.7	3/5V1870E	E	6A	5/16"	2-5/8"	1/16"	46.6	
21.2	3/5V2120E	E	6A	11/16"	2-5/8"	7/16"	57.2	
23.6	3/5V2360E	E	6A	11/32"	2-5/8"	3/32"	73	
28	3/5V2800E	E	6A	5/16"	2-5/8"	1/16"	97	
31.5	3/5V3150F	F	5A	31/32"	3-5/8"	9/32"	128	
37.5	3/5V3750F	F	5A	31/32"	3-5/8"	9/32"	158	
50	3/5V5000F	F	5A	31/32"	3-5/8"	9/32"	218	

Bore Range	Keysteat
1/2"-9/16"	1/8" x 1/16"
5/8"-7/8"	3/16" x 3/32"
15/16"-1-1/4"	1/4" x 1/8"
1-5/16"-1-3/8"	5/16" x 5/32"
1-7/16"-1-3/4"	3/8" x 3/16"
1-13/16"-2-1/4"	1/2" x 1/4"
2-5/16"-2-3/4"	5/8" x 5/16"
2-13/16"-3-1/4"	3/4" x 3/8"
3-3/8"-3-3/4"	7/8" x 7/16"
3-7/8"-4-1/4"	1" x 1/2"

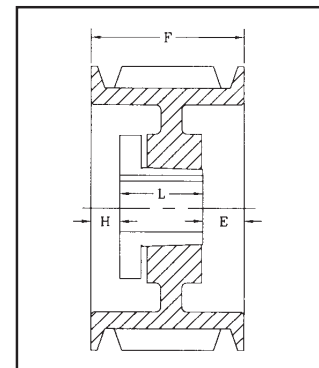

**DRAWING TYPE 1 (1A, 1B, 1W)**



# QD SHEAVES & BUSHINGS

## "5V" Section

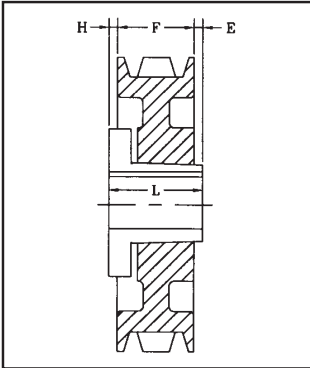

**DRAWING TYPE 5 (5A)**

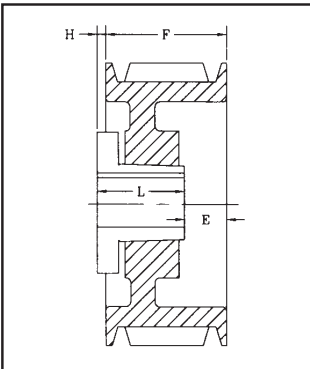

**DRAWING TYPE 6 (6A, 6B, 6W)**

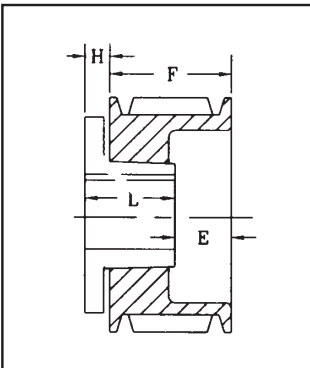

**DRAWING TYPE 11 (11B)**

**4-GROOVE ("F" DIMENSION = 3-1/16")**

Diameter Outside	Four Groove	Bushing Type	Drawing	"H"	"L"	"E"	Wt. Lbs.
4.4	4/5V440SD	SD	11B	11/16"	1-13/16"	2-5/8"	6.3
4.65	4/5V465SD	SD	11B	11/16"	1-13/16"	2-5/8"	7
4.9	4/5V490SD	SD	1B	5/8"	1-13/16"	1-5/16"	7.9
5.2	4/5V520SD	SD	1B	5/8"	1-13/16"	1-5/16"	9.7
5.5	4/5V550SD	SD	1B	5/8"	1-13/16"	1-5/16"	10.9
5.9	4/5V590SD	SD	1B	1/2"	1-7/8"	1-3/8"	11.2
6.3	4/5V630SK	SK	1B	1/2"	1-7/8"	1-3/8"	12.2
6.7	4/5V670SK	SK	1B	1/2"	2"	1-1/4"	13.2
7.1	4/5V710SF	SF	1B	5/16"	2"	1-7/16"	16.7
7.5	4/5V750SF	SF	1B	5/16"	2"	1-7/16"	18.5
8	4/5V800E	E	1B	5/16"	2-5/8"	13/16"	20
8.5	4/5V850E	E	1B	5/16"	2-5/8"	13/16"	24.4
9	4/5V900E	E	1B	5/16"	2-5/8"	13/16"	27.4
9.25	4/5V925E	E	1B	5/16"	2-5/8"	13/16"	29.2
9.75	4/5V975E	E	1B	5/16"	2-5/8"	13/16"	32.8
10.3	4/5V1030E	E	1W	5/16"	2-5/8"	13/16"	31.1
10.9	4/5V1090E	E	1W	5/16"	2-5/8"	13/16"	33
11.3	4/5V1130E	E	1W	5/16"	2-5/8"	13/16"	35
11.8	4/5V1180E	E	1W	5/16"	2-5/8"	13/16"	37.3
12.5	4/5V1250E	E	1W	5/16"	2-5/8"	13/16"	38.9
13.2	4/5V1320E	E	1W	5/16"	2-5/8"	13/16"	41.8
14	4/5V1400E	E	1A	5/16"	2-5/8"	13/16"	45.3
15	4/5V1500E	E	1A	5/16"	2-5/8"	13/16"	49.1
16	4/5V1600E	E	1A	5/16"	2-5/8"	13/16"	51.9
18.7	4/5V1870E	E	6A	9/32"	3-5/8"	13/32"	86
21.2	4/5V2120E	E	6A	7/32"	3-5/8"	11/32"	84.7
23.6	4/5V2360F	F	6A	7/32"	3-5/8"	11/32"	111
28	4/5V2800F	F	6A	7/32"	3-5/8"	11/32"	128
31.5	4/5V3150F	F	6A	1-9/64"	4-1/2"	25/64"	174
37.5	4/5V3750F	F	6A	7/8"	4-1/2"	1/8"	199
50	4/5V5000J	J	6A	7/8"	4-1/2"	1/8"	319

**5-GROOVE ("F" DIMENSION = 3-3/4")**

Diameter Outside	Five Groove	Bushing Type	Drawing	"H"	"L"	"E"	Wt. Lbs.
4.4	5/5V440SD	SD	11B	11/16"	1-13/16"	2-5/8"	6.3
4.65	5/5V465SD	SD	11B	11/16"	1-13/16"	2-5/8"	7
4.9	5/5V490SD	SD	1B	5/8"	1-13/16"	1-5/16"	7.9
5.2	5/5V520SD	SD	1B	5/8"	1-13/16"	1-5/16"	9.7
5.5	5/5V550SD	SD	1B	5/8"	1-13/16"	1-5/16"	10.9
5.9	5/5V590SK	SK	1B	1/2"	1-7/8"	1-3/8"	11.2
6.3	5/5V630SK	SK	1B	1/2"	1-7/8"	1-3/8"	12.2
6.7	5/5V670SD	SF	1B	1/2"	2"	1-1/4"	13.2
7.1	5/5V710SF	SF	1B	5/16"	2"	1-7/16"	16.7
7.5	5/5V750SF	SF	1B	5/16"	2"	1-7/16"	18.5
8	5/5V800E	E	1B	5/16"	2-5/8"	13/16"	20
8.5	5/5V850E	E	1B	5/16"	2-5/8"	13/16"	24.4
9	5/5V900E	E	1B	5/16"	2-5/8"	13/16"	27.4
9.25	5/5V925E	E	1B	5/16"	2-5/8"	13/16"	29.2
9.75	5/5V975E	E	1B	5/16"	2-5/8"	13/16"	32.8
10.3	5/5V1030E	E	1W	5/16"	2-5/8"	13/16"	31.1
10.9	5/5V1090E	E	1W	5/16"	2-5/8"	13/16"	33
11.3	5/5V1130E	E	1W	5/16"	2-5/8"	13/16"	35
11.8	5/5V1180E	E	1W	5/16"	2-5/8"	13/16"	37.3
12.5	5/5V1250E	E	1W	5/16"	2-5/8"	13/16"	38.9
13.2	5/5V1320E	E	1W	5/16"	2-5/8"	13/16"	41.8
14	5/5V1400E	E	1A	5/16"	2-5/8"	13/16"	45.3
15	5/5V1500E	E	1A	5/16"	2-5/8"	13/16"	49.1
16	5/5V1600E	E	1A	5/16"	2-5/8"	13/16"	51.9
18.7	5/5V1870F	F	6A	9/32"	3-5/8"	13/32"	86
21.2	5/5V2120F	F	6A	7/32"	3-5/8"	11/32"	84.7
23.6	5/5V2360F	F	6A	7/32"	3-5/8"	11/32"	111
28	5/5V2800F	F	6A	7/32"	3-5/8"	11/32"	128
31.5	5/5V3150J	J	6A	1-9/64"	4-1/2"	25/64"	174
37.5	5/5V3750J	J	6A	7/8"	4-1/2"	1/8"	199
50	5/5V5000J	J	6A	7/8"	4-1/2"	1/8"	319

**QD SHEAVES & BUSHINGS**  
**"5V" Section**

**AVAILABLE**  
**QD BUSHING BORE**  
**SIZES**

6-GROOVE ("F" DIMENSION = 4-7/16")	Diameter Outside	Six Groove	Bushing Type	Drawing	"H"	"L"	"E"	Wt. Lbs.	Part No.	Key Seat	Part No.	Key Seat
	4.4	6/5V440SD	SD	11B	11/16"	1-13/16"	3-5/16"	8.4	E-7/8	3/16 x 3/32	F-1-3/16	1/4 x 1/8
	4.65	6/5V465SD	SD	11B	11/16"	1-13/16"	3-5/16"	9.3	E-15/16	1/4 x 1/8	F-1-1/4	1/4 x 1/8
	4.9	6/5V490SD	SD	1B	5/8"	1-13/16"	2"	8.9	E-1	1/4 x 1/8	F-1-3/8	5/16 x 5/32
	5.2	6/5V520SD	SD	1B	5/8"	1-13/16"	2"	10.9	E-1-1/8	1/4 x 1/8	F-1-7/16	3/8 x 3/16
	5.5	6/5V550SD	SD	1B	5/8"	1-13/16"	2"	13.4	E-1-3/16	1/4 x 1/8	F-1-1/2	3/8 x 3/16
	5.9	6/5V590SK	SK	1B	1/2"	1-7/8"	2-1/16"	12.8	E-1-1/4	1/4 x 1/8	F-1-9/16	3/8 x 3/16
	6.3	6/5V630SK	SK	1B	1/2"	1-7/8"	2-1/16"	15.3	E-1-5/16	5/16 x 3/32	F-1-5/8	3/8 x 3/16
	6.7	6/5V670SF	SF	1B	13/16"	2"	1-5/8"	16.1	E-1-3/8	5/16 x 3/32	F-1-11/16	3/8 x 3/16
	7.1	6/5V710SF	SF	1B	9/16"	2"	1-7/8"	18.8	E-1-7/16	3/8 x 3/16	F-1-3/4	3/8 x 3/16
7.5	6/5V750SF	SF	1B	9/16"	2"	1-7/8"	20.8	E-1-1/2	3/8 x 3/16	F-1-13/16	3/8 x 3/16	
8	6/5V800E	E	1B	9/16"	2-5/8"	1-1/4"	22.3	E-1-9/16	3/8 x 3/16	F-1-7/8	1/2 x 1/4	
8.5	6/5V850E	E	1B	9/16"	2-5/8"	1-1/4"	27.1	E-1-5/8	3/8 x 3/16	F-1-15/16	1/2 x 1/4	
9	6/5V900E	E	1B	9/16"	2-5/8"	1-1/4"	30.5	E-1-11/16	3/8 x 3/16	F-2	1/2 x 1/4	
9.25	6/5V925E	E	1B	9/16"	2-5/8"	1-1/4"	32.2	E-1-3/4	3/8 x 3/16	F-2-1/16	1/2 x 1/4	
9.75	6/5V975E	E	1B	9/16"	2-5/8"	1-1/4"	36.2	E-1-13/16	1/2 x 1/4	F-2-1/8	1/2 x 1/4	
10.3	6/5V1030E	E	1W	9/16"	2-5/8"	1-1/4"	34.4	E-1-7/8	1/2 x 1/4	F-2-3/16	1/2 x 1/4	
10.9	6/5V1090E	E	1W	9/16"	2-5/8"	1-1/4"	36.4	E-1-15/16	1/2 x 1/4	F-2-1/4	1/2 x 1/4	
11.3	6/5V1130E	E	1W	9/16"	2-5/8"	1-1/4"	39.3	E-2	1/2 x 1/4	F-2-5/16	5/8 x 5/16	
11.8	6/5V1180E	E	1W	9/16"	2-5/8"	1-1/4"	40.2	E-2-1/16	1/2 x 1/4	F-2-3/8	5/8 x 5/16	
12.5	6/5V1250F	F	1W	17/32"	3-5/8"	9/32"	54.2	E-2-1/8	1/2 x 1/4	F-2-1/2	5/8 x 5/16	
13.2	6/5V1320F	F	1W	17/32"	3-5/8"	9/32"	58	E-2-3/16	5/8 x 5/16	F-2-11/16	5/8 x 5/16	
14	6/5V1400F	F	1W	17/32"	3-5/8"	9/32"	59.9	E-2-7/16	5/8 x 5/16	F-2-3/4	5/8 x 5/16	
15	6/5V1500F	F	1A	17/32"	3-5/8"	9/32"	60	E-2-1/2	5/8 x 5/16	F-2-13/16	3/4 x 3/8	
16	6/5V1600F	F	1A	17/32"	3-5/8"	9/32"	64.7	E-2-9/16	5/8 x 5/16	F-2-7/8	3/4 x 3/8	
18.7	6/5V1870F	F	1A	3/32"	3-5/8"	23/32"	80.5	E-2-5/8	5/8 x 5/16	F-2-15/16	3/4 x 3/8	
21.2	6/5V2120F	F	6A	7/32"	3-5/8"	1-1/32"	96.3	E-2-11/16	5/8 x 5/16	F-3	3/4 x 3/8	
23.6	6/5V2360J	J	6A	15/32"	4-1/2"	13/32"	133	E-2-3/4	5/8 x 5/16	F-3-1/8	3/4 x 3/8	
28	6/5V2800J	J	6A	15/32"	4-1/2"	13/32"	179	E-2-13/16	3/4 x 3/8	F-3-1/4	3/4 x 3/8	
31.5	6/5V3150J	J	6A	15/32"	4-1/2"	13/32"	198	E-2-7/8	3/4 x 3/8	F-3-1/2	3/4 x 3/8	
37.5	6/5V3750J	J	6A	15/32"	4-1/2"	13/32"	239	E-2-15/16	3/4 x 3/8	F-3-5/16	7/8 x 3/16	
50	6/5V5000M	M*	5A	1-13/32"	6-3/4"	29/32"	386	E-3	3/4 x 3/8	F-3-3/8	7/8 x 3/16	
								E-3-1/8	3/4 x 3/8	F-3-7/16	7/8 x 3/16	
								E-3-3/16	3/4 x 3/8	F-3-1/2	7/8 x 3/16	
								E-3-1/4	3/4 x 3/8	F-3-5/8	7/8 x 3/16	
								E-3-5/16	7/8 x 1/16	F-3-11/16	7/8 x 3/16	
								E-3-3/8	7/8 x 1/16	F-3-3/4	7/8 x 3/16	
								E-3-7/16	7/8 x 1/16	F-3-7/8	1 x 1/8	
								E-3-1/2	7/8 x 1/16	F-3-15/16	1 x 1/8	
								F-1	1/4 x 1/8	F-4	no KS	
								F-1-1/8	1/4 x 1/8			

\* M-N-P bushings are standard mounting only.

**QD BUSHINGS**

\*continued on next page

Part Number	Torque Capacity (In/Lbs)	DIAMETERS					CAPSCREWS		Bore Min.	Bore Max	Weight
		A	B	D	E	L	Size	Bolt Circle M			
JA	1,000	5/16"	1-3/8"	2"	11/16"	1"	10-24 x 1	1-21/32"	1/2"	1-1/4"	0.4
H	1,750	1/4"	1-5/8"	2-1/2"	1"	1-1/4"	1/4-20 x 1	2"	3/8"	1-3/8"	0.8
SH	3,500	7/16"	1-27/31"	2-5/8"	3/4"	1-5/16"	1/4-20 x 1-3/8	2-1/4"	1/2"	1-11/16"	1
SDS	5,000	7/16"	2-3/16"	3-1/8"	3/4"	1-5/16"	1/4-20 x 1-3/8	2-11/16"	1/2"	2"	1.2
SD	5,000	7/16"	2-3/16"	3-1/8"	1-1/4"	1-13/16"	1/4-20 x 1-7/8	2-11/16"	1/2"	2"	15
SK	7,000	9/16"	2-13/16"	3-7/8"	1-1/4"	1-15/16"	5/16-18 x 2	3-5/16"	1/2"	2-1/2"	2
SF	11,000	5/8"	3-1/8"	4-5/8"	1-1/4"	2-1/16"	3/8-16 x 2	3-7/8"	1/2"	2-15/16"	3.5
E	20,000	7/8"	3-5/6"	6"	1-5/8"	2-3/4"	1/2-13 x 2-3/4	5"	7/8"	3-1/4"	9
F	40,000	1"	4-7/16"	6-5/8"	2-1/2"	3-3/4"	9/16-12 x 3-5/8	5-5/8"	1"	4"	14
J	55,000	1-1/8"	5-10/69"	7-1/4"	3-3/16"	4-5/8"	5/8-11 x 4-1/2	6-1/4"	1-1/2"	4-1/2"	22
M	125,000	1-1/4"	6-1/2"	9"	5-3/16"	6-3/4"	3/4-10 x 6-3/4	7-7/8"	2"	5-1/2"	51
N	150,000	1-1/2"	7"	10"	6-1/4"	8-1/8"	7/8-9 x 9-1/2	8-1/2"	2-7/8"	5-7/8"	66
P	250,000	1-3/4"	8-15/62"	11-3/4"	7-1/4"	9-3/8"	1-8 x 9-1/2	10"	2-15/16"	7"	122

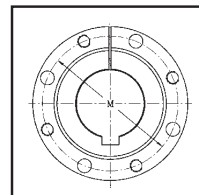
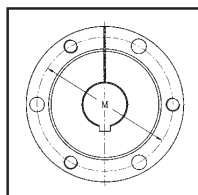
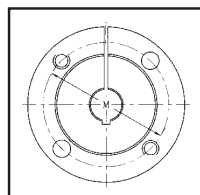
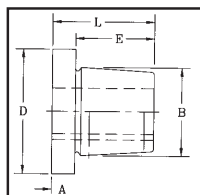

**Bushing Nomenclature**

**SD - 1/2**

↑ Bushing Type    ↑ Bore Size

# AVAILABLE QD BUSHING BORE SIZES

Part No.	Key Seat	Part No.	Key Seat	Part No.	Key Seat	Part No.	Key Seat	Part No.	Key Seat	Part No.	Key Seat
H-7/16	No KS	J-3-7/8	1 x 3/8	M-4-11/16	1-1/4 x 5/8	P-5-3/16	1-1/4 x 5/8	SDS-1-1/2	3/8 x 3/16	SH-1-1/16	1/4 x 1/8
H-1/2	1/8 x 1/16	J-3-15/16	1 x 3/8	M-4-3/4	1-1/4 x 5/8	P-5-1/4	1-1/4 x 5/8	SDS-1-9/16	3/8 x 3/16	SH-1-1/8	1/4 x 1/8
H-9/16	1/8 x 1/16	J-4	1 x 1/8	M-4-7/8	1-1/4 x 5/8	P-5-3/8	1-1/4 x 5/8	SDS-1-5/8	3/8 x 3/16	SH-1-3/16	1/4 x 1/8
H-5/8	3/16 x 3/32	J-4-1/8	1 x 1/8	M-4-15/16	1-1/4 x 5/8	P-5-7/16	1-1/4 x 5/8	SDS-1-11/16	3/8 x 3/16	SH-1-1/4	1/4 x 1/8
H-11/16	3/16 x 3/32	J-4-3/16	1 x 1/8	M-5	1-1/4 x 5/8	P-5-1/2	1-1/4 x 5/8	SDS-1-3/4	3/8 x 1/8	SH-1-5/16	5/16 x 5/32
H-3/4	3/16 x 3/32	J-4-1/4	1 x 1/8	M-5-3/16	1-1/4 x 5/8	P-5-5/16	1-1/4 x 5/8	SDS-1-13/16	1/2 x 1/8	SH-1-3/8	5/16 x 5/32
H-13/16	3/16 x 3/32	J-4-3/8	1 x 1/8	M-5-1/4	1-1/4 x 5/8	P-5-3/4	1-1/2 x 3/4	SDS-1-7/8	1/2 x 1/16	SH-1-7/16	3/8 x 1/16
H-7/8	3/16 x 3/32	J-4-7/16	1 x 1/8	M-5-7/16	1-1/4 x 5/8	P-5-7/8	1-1/2 x 1/4	SDS-1-15/16	1/2 x 1/16	SH-1-1/2	3/8 x 1/16
H-15/16	1/4 x 1/8	J-4-1/2	1 x 1/8	M-5-1/2	1-1/4 x 5/8	P-5-15/16	1-1/2 x 1/4	SDS-2	No KS	SH-1-9/16	3/8 x 1/16
H-1	1/4 x 1/8	JA-1/2	1/8 x 1/16	N-2-15/16	3/4 x 3/8	P-6	1-1/2 x 1/4	SF-1/2	1/8 x 1/16	SH-1-5/8	3/8 x 1/16
H-1-1/16	1/4 x 1/8	JA-9/16	1/8 x 1/16	N-3	3/4 x 3/8	P-6-1/16	1-1/2 x 1/4	SF-5/8	3/16 x 3/32	SH-1-1/16	No KS
H-1-1/8	1/4 x 1/8	JA-5/8	3/16 x 3/32	N-3-3/8	7/8 x 7/16	P-6-1/4	1-1/2 x 1/4	SF-3/4	3/16 x 3/32	SK-1/2	1/8 x 1/16
H-1-1/16	1/4 x 1/8	JA-11/16	3/16 x 3/32	N-3-7/16	7/8 x 7/16	P-6-7/16	1-1/2 x 1/4	SF-7/8	3/16 x 3/32	SK-9/16	1/8 x 1/16
H-1-1/8	1/4 x 1/8	JA-3/4	3/16 x 3/32	N-3-1/2	7/8 x 7/16	P-6-1/2	1-1/2 x 1/4	SF-15/16	1/4 x 1/8	SK-5/8	3/16 x 3/32
H-1-3/16	1/4 x 1/8	JA-13/16	3/16 x 3/32	N-3-5/8	7/8 x 7/16	P-6-3/4	1-3/4 x 1/8	SF-1-1/16	1/4 x 1/8	SK-11/16	3/16 x 3/32
H-1-1/4	1/4 x 1/8	JA-7/8	3/16 x 3/32	N-3-3/4	7/8 x 7/16	P-7	1-3/4 x 1/8	SF-1-1/8	1/4 x 1/8	SK-3/4	3/16 x 3/32
H-5-16	5/16 x 1/16	JA-15/16	1/4 x 1/8	N-3-7/8	1 x 1/2	SD-3/4	3/16 x 3/32	SF-1-3/16	1/4 x 1/8	SK-3/16	3/16 x 3/32
H-1-3/8	5/16 x 1/16	JA-1	1/4 x 1/8	N-3-15/16	1 x 1/2	SD-13/16	3/16 x 3/32	SF-1-1/4	1/4 x 1/8	SK-7/8	3/16 x 3/32
H-1-7/16	3/8 x 1/16	JA-1-1/16	1/4 x 1/16	N-4	1 x 1/2	SD-7/8	3/16 x 3/32	SF-1-5/16	5/16 x 5/32	SK-15/16	1/4 x 1/8
H-1-1/2	3/8 x 1/16	JA-1-1/8	1/4 x 1/16	N-4-3/16	1 x 1/2	SD-15/16	1/4 x 1/8	SF-1-3/8	5/16 x 5/32	SK-1	1/4 x 1/8
J-1-7/16	3/8 x 3/16	JA-1-3/16	1/4 x 1/16	N-4-1/4	1 x 1/2	SD-1	1/4 x 1/8	SF-1-7/16	3/8 x 3/16	SK-1-1/16	1/4 x 1/8
J-1-1/2	3/8 x 3/16	JA-1-1/4	1/4 x 1/32	N-4-3/8	1 x 1/2	SD-1-1/16	1/4 x 1/8	SF-1-1/2	3/8 x 3/16	SK-1-1/8	1/4 x 1/8
J-1-9/16	3/8 x 3/16	M-1-15/16	1/2 x 1/4	N-4-7/16	1 x 1/2	SD-1-1/8	1/4 x 1/8	SF-1-9/16	3/8 x 3/16	SK-1-3/16	1/4 x 1/8
J-1-11/16	3/8 x 3/16	M-2	1/2 x 1/4	N-4-1/2	1 x 1/2	SD-1-3/16	1/4 x 1/8	SF-1-5/8	3/8 x 3/16	SK-1-1/4	1/4 x 1/8
J-1-3/4	3/8 x 3/16	M-2-3/16	1/2 x 1/4	N-4-5/8	1-1/4 x 5/8	SD-1-1/4	1/4 x 1/8	SF-1-11/16	3/8 x 3/16	SK-1-5/16	5/16 x 5/32
J-1-7/8	1/2 x 1/4	M-2-1/4	1/2 x 1/4	N-4-3/4	1-1/4 x 5/8	SD-1-5/16	5/16 x 5/32	SF-1-3/4	3/8 x 3/16	SK-1-3/8	5/16 x 5/32
J-1-15/16	1/2 x 1/4	M-2-3/8	5/8 x 5/16	N-4-7/8	1-1/4 x 5/8	SD-1-3/8	5/16 x 5/32	SF-1-13/16	1/2 x 1/4	SK-1-7/16	3/8 x 3/16
J-2	1/2 x 1/4	M-2-7/16	5/8 x 5/16	N-4-15/16	1-1/4 x 5/8	SD-1-7/16	3/8 x 3/16	SF-1-7/8	1/2 x 1/4	SK-1-1/2	3/8 x 3/16
J-2-1/16	1/2 x 1/4	M-2-1/2	5/8 x 5/16	N-5	1-1/4 x 5/8	SD-1-1/2	3/8 x 3/16	SF-1-15/16	1/2 x 1/4	SK-1-9/16	3/8 x 3/16
J-2-1/8	1/2 x 1/4	M-2-5/8	5/8 x 5/16	N-5-3/16	1-1/4 x 1/4	SD-1-9/16	3/8 x 3/16	SF-2	1/2 x 1/4	SK-1-5/8	3/8 x 3/16
J-2-3/16	1/2 x 1/4	M-2-11/16	5/8 x 5/16	N-5-7/16	1-1/4 x 1/4	SD-1-5/8	3/8 x 3/16	SF-2-1/16	1/2 x 1/4	SK-1-11/16	3/8 x 3/16
J-2-1/4	1/2 x 1/4	M-2-3/4	5/8 x 5/16	N-5-1/2	1-1/4 x 1/4	SD-1-11/16	3/8 x 3/16	SF-2-1/8	1/2 x 1/4	SK-1-3/4	3/8 x 3/16
J-2-5/16	5/8 x 5/16	M-2-7/8	3/4 x 3/8	N-5-7/8	1-1/2 x 1/4	SD-1-3/4	3/8 x 3/16	SF-2-3/16	1/2 x 1/4	SK-1-13/16	1/2 x 1/4
J-2-3/8	5/8 x 5/16	M-2-15/16	3/4 x 3/8	N-5-15/16	1-1/2 x 1/8	SD-1-13/16	1/2 x 1/8	SF-2-1/4	1/2 x 1/4	SK-1-7/8	1/2 x 1/4
J-2-7/16	5/8 x 5/16	M-3	3/4 x 3/8	P-2-15/16	3/4 x 3/8	SD-1-7/8	1/2 x 1/8	SF-2-5/16	5/8 x 3/16	SK-1-15/16	1/2 x 1/4
J-2-1/2	5/8 x 5/16	M-3-1/8	3/4 x 3/8	P-3-1/4	3/4 x 3/8	SD-1-15/16	1/2 x 1/16	SF-2-3/8	5/8 x 3/16	SK-2	1/2 x 1/4
J-2-5/8	5/8 x 5/16	M-3-3/16	3/4 x 3/8	P-3-7/16	7/8 x 7/16	SD-2	No KS	SF-2-7/16	5/8 x 3/16	SK-1-1/16	1/2 x 1/4
J-2-11/16	5/8 x 5/16	M-3-1/4	3/4 x 3/8	P-3-1/2	7/8 x 7/16	SDS-1/2	1/8 x 1/16	SF-2-1/2	5/8 x 3/16	SK-2-1/8	1/2 x 1/4
J-2-3/4	5/8 x 5/16	M-3-5/8	7/8 x 7/16	P-3-5/8	7/8 x 7/16	SDS-9/16	1/8 x 1/16	SF-2-9/16	5/8 x 1/16	SK-2-3/16	1/2 x 1/8
J-2-7/8	3/4 x 3/8	M-3-7/16	7/8 x 7/16	P-3-3/4	7/8 x 7/16	SDS-5/8	3/16 x 3/32	SF-2-5/8	5/8 x 1/16	SK-2-1/4	1/2 x 1/8
J-2-15/16	3/4 x 3/8	M-3-1/2	7/8 x 7/16	P-3-7/8	1 x 1/2	SDS-11/16	3/16 x 3/32	SF-2-11/16	5/8 x 1/16	SK-2-5/16	5/8 x 1/16
J-3	3/4 x 3/8	M-3-5/8	7/8 x 7/16	P-3-15/16	1 x 1/2	SDS-3/4	3/16 x 3/32	SF-2-3/4	5/8 x 1/16	SK-2-3/8	5/8 x 1/16
J-3-1/8	3/4 x 3/8	M-3-11/16	7/8 x 7/16	P-4	1 x 1/2	SDS-13/16	3/16 x 3/32	SF-2-7/8	3/4 x 1/16	SK-2-7/16	5/8 x 1/16
J-3-3/16	3/4 x 3/8	M-3-3/4	7/8 x 7/16	P-4-1/4	1 x 1/2	SDS-7/8	3/16 x 3/32	SF-2-15/16	3/4 x 1/32	SK-2-1/2	5/8 x 1/16
J-3-1/4	3/4 x 3/8	M-3-7/8	1 x 1/2	P-4-3/8	1 x 1/2	SDS-15/16	1/4 x 1/8	SH-1/2	1/8 x 1/16	SK-2-9/16	No KS
J-3-5/16	7/8 x 7/16	M-3-15/16	1 x 1/2	P-4-7/16	1 x 1/2	SDS-1	1/4 x 1/8	SH-9/16	1/8 x 1/16	SK-2-5/8	No KS
J-3-3/8	7/8 x 7/16	M-4	1 x 1/2	P-4-1/2	1 x 1/2	SDS-1-1/16	1/4 x 1/8	SH-5/8	3/16 x 3/32		
J-3-7/16	7/8 x 7/16	M-4-1/8	1 x 1/2	P-4-5/8	1-1/4 x 5/8	SDS-1-1/8	1/4 x 1/8	SH-11/16	3/16 x 3/32		
J-3-1/2	7/8 x 7/16	M-4-3/16	1 x 1/2	P-4-11/16	1-1/4 x 5/8	SDS-1-3/16	1/4 x 1/8	SH-3/4	3/16 x 3/32		
J-3-5/8	7/8 x 7/16	M-4-1/4	1 x 1/2	P-4-3/4	1-1/4 x 5/8	SDS-1-1/4	1/4 x 1/8	SH-13/16	3/16 x 3/32		
J-3-11/16	7/8 x 7/16	M-4-3/8	1 x 1/2	P-4-7/8	1-1/4 x 5/8	SDS-1-5/16	5/16 x 5/32	SH-7/8	3/16 x 3/32		
J-3-3/4	7/8 x 7/16	M-4-7/16	1 x 1/2	P-4-15/16	1-1/4 x 5/8	SDS-1-3/8	5/16 x 5/32	SH-15/16	1/4 x 1/8		
J-3-13/16	1 x 1/2	M-4-1/2	1 x 1/2	P-5	1-1/4 x 5/8	SDS-1-7/16	3/8 x 3/16	SH-1	1/4 x 1/8		

## SHEAVES - Split Taper Bushings

Part No.	Bushing Type	Outside	Inside	"A" Datum	"B" Datum	Drawing	Wt. Lbs.
2TB34P1	P1	3.75		3.00	3.40	1	2.9
2TB36P1	P1	3.95		3.20	3.60	1	2.3
2TB38P1	P1	4.15	2.31	3.40	3.80	2	3.8
2TB42P1	P1	4.35	2.50	3.60	4.00	2	3.9
2TB46P1	P1	4.95	2.88	4.00	4.40	3-SOL	4.6
2TB48P1	P1	5.15	3.31	4.40	4.80	3-SOL	5.3
2TB50P1	P1	5.35	3.50	4.60	5.00	3-SOL	5.6
2TB52P1	P1	5.55		4.80	5.20	3	4.1
2TB54P1	P1	5.75	3.88	5.00	5.40	3-SOL	6.5
2TB58P1	P1	6.15	4.31	5.40	5.80	3-SOL	8.0
2TB64P1	P1	6.75	4.88	6.00	6.40	3-WEB	7.8
2TB68P1	P1	7.15	5.31	6.40	6.80	3-WEB	8.8
2TB70Q1	Q1	7.35	5.50	6.60	7.00	3-WEB	11.1
2TB74Q1	Q1	7.75	5.94	7.00	7.40	3-WEB	11.5
2TB80Q1	Q1	8.35	6.50	7.60	8.00	3-WEB	12.8
2TB94Q1	Q1	9.35	7.50	8.60	9.00	3-ARM	16.5
2TB110Q1	Q1	11.35	9.44	10.60	11.00	3-ARM	18.9
2TB124Q1	Q1	12.75	10.94	12.00	12.40	3-ARM	21.1

Item	5/8"	3/4"	7/8"	1"	1-1/16"	1-1/8"	Wt./Lbs.
P1	P1-5/8	P1-3/4	P1-7/8	P1-1	P1-1-1/16	P1-1-1/8	1.3
Q1				Q1-1		Q1-1-1/8	3.5

Item	1-3/16"	1-1/4"	1-3/8"	1-5/8"	1-1/2"	1-7/16"	Wt./Lbs.
P1	P1-1-3/16	P1-1-1/4	P1-1-3/8	P1-1-5/8	P1-1-1/2	P1-1-7/16	1.3
Q1	Q1-1-3/16		Q1-1-3/8	Q1-1-5/8		Q1-1-7/16	3.5

Item	1-11/16"	1-15/16"	Wt./Lbs.
P1			1.3
Q1	Q1-1-11/16	Q1-1-15/16	3.5

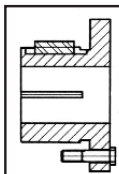
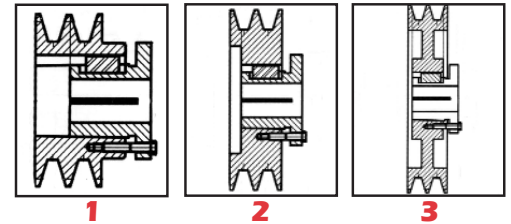

Standard Keyseat	
Bore Range	Keyseat
1/2"-9/16"	1/8" x 1/16"
5/8"-7/8"	3/16" x 3/32"
15/16"-1-1/4"	1/4" x 1/8"
1-5/16"-1-3/8"	5/16" x 5/32"
1-7/16"-1-3/4"	3/8" x 3/16"
1-13/16"-2-1/4"	1/2" x 1/4"
2-5/16"-2-3/4"	5/8" x 5/16"
2-13/16"-3-1/4"	3/4" x 3/8"
3-3/8"-3-3/4"	7/8" x 7/16"
3-7/8"-4-1/4"	1" x 1/2"

# TECHNICAL DATA

To assure maximum service from a drive, use the **Jason Sheave Gauge (Part Number G001)** (Fig. 1) to inspect sheaves every time a belt is replaced.

- Inspect for burrs or rough spots along the sheave rim.
- Check to make sure side walls are not dished out (Fig. 2). On multiple belt drive, it is essential that all grooves have no wear. Wear on one groove and not another will create “differential driving” (Fig. 3) and is equivalent to running a mismatched set of belts.
- Check for shiny grooves in sheave. Shiny grooves indicate a worn spot that will wear replacement belt.
- Check the alignment of sheaves and that the shafts are parallel.

Failure to replace a worn sheave will result in poor performance and premature failure of the drive belt.

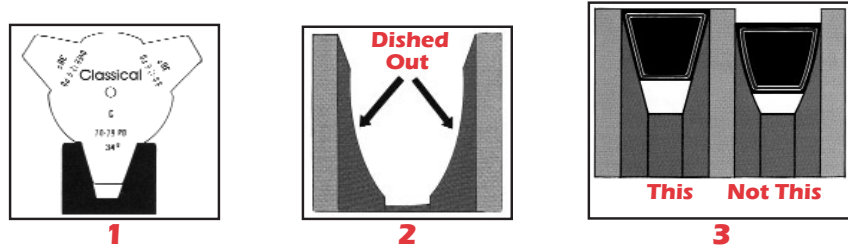

**VARIABLE PITCH DIAMETERS (Inches)**

Belt	Pitch Line Diameters (inches)										
	1VP	2VP	Min.	Max.	0 Turn Close	1 Turn Open	2 Turns Open	3 Turns Open	4 Turns Open	5 Turns Open	6 Turns Open
3L Belt	1VP25		1.6	2.4	2.4	2.2	2.0	1.8	1.6	-	-
	1VP34		1.7	2.5	2.5	2.3	2.1	1.9	1.7	-	-
		2VP36	1.9	2.7	2.7	2.5	2.3	2.1	1.9	-	-
	1VP40		2.3	3.1	3.1	2.9	2.7	2.5	2.3	-	-
		2VP42	2.5	3.3	3.3	3.1	2.9	2.7	2.5	-	-
	1VP44		2.7	3.5	3.5	3.3	3.1	2.9	2.7	-	-
	1VP50	2VP50	3.3	4.4	4.1	3.9	3.7	3.5	3.3	-	-
	1VP56	2VP56	3.9	4.7	4.7	4.5	4.3	4.1	3.9	-	-
	1VP60	2VP60	-	-	-	-	-	-	-	-	-
	1VP62	2VP62	4.5	5.3	5.3	5.1	4.9	4.7	4.5	-	-
1VP65	2VP65	-	-	-	-	-	-	-	-	-	
1VP68	2VP68	5.1	5.9	5.9	5.7	5.5	5.3	5.1	-	-	
"A" or "4L" Belt	1VP34		1.9	2.9	2.9	2.7	2.5	2.3	2.1	1.9	-
		2VP36	2.0	3.0	3.0	2.8	2.6	2.4	2.2	2.0	-
	1VP40		2.4	3.4	3.4	3.2	3.0	2.8	2.6	2.4	-
		2VP42	2.6	3.6	3.6	3.4	3.2	3.0	2.8	2.6	-
	1VP44		2.8	3.8	3.8	3.6	3.4	3.2	3.0	2.8	-
	1VP50	2VP50	3.4	4.4	4.4	4.2	4.0	3.8	3.6	3.4	-
	1VP56	2VP56	4.0	5.0	5.0	4.8	4.6	4.4	4.2	4.0	-
	1VP60	2VP60	4.2	5.2	5.2	5.0	4.8	4.6	4.4	4.2	-
	1VP62	2VP62	4.6	5.6	5.6	5.4	5.2	5.0	4.8	4.6	-
	1VP65	2VP65	4.7	5.7	5.7	5.5	5.3	5.1	4.9	4.7	-
1VP68	2VP68	5.2	6.2	6.2	6.0	5.8	5.6	5.4	5.2	-	
1VP71	2VP71	5.3	6.3	6.3	6.1	5.9	5.7	5.5	5.3	-	
1VP75	2VP75	5.7	6.7	6.7	6.5	6.3	6.1	5.9	5.7	-	
"B" or "5L" Belt	1VP34		2.4	3.2	-	3.2	3.0	2.8	2.6	2.4	-
		2VP36	2.5	3.3	-	3.3	3.1	2.9	2.7	2.5	-
	1VP40		2.7	3.7	-	3.7	3.5	3.3	3.1	2.9	2.7
		2VP42	2.9	3.9	-	3.9	3.7	3.5	3.3	3.1	2.9
	1VP44		3.1	4.1	-	4.1	3.9	3.7	3.5	3.3	3.1
	1VP50	2VP50	3.7	4.7	-	4.7	4.5	4.3	4.1	3.9	3.7
	1VP56	2VP56	4.3	5.3	-	5.3	5.1	4.9	4.7	4.5	4.3
	1VP60	2VP60	4.3	5.5	5.5	5.3	5.1	4.9	4.7	4.5	4.3
	1VP62	2VP62	4.9	5.9	-	5.9	5.7	5.5	5.3	5.1	4.9
	1VP65	2VP65	4.8	6.0	6.0	5.8	5.6	5.4	5.2	5.0	4.8
1VP68	2VP68	5.5	6.5	-	6.5	6.3	6.1	5.9	5.7	5.5	
1VP71	2VP71	5.4	6.6	6.6	6.4	6.2	6.0	5.8	5.6	5.4	
1VP75	2VP75	5.8	7.0	7.0	6.8	6.6	6.4	6.2	6.0	5.8	
"5V" Belts	1VP62	2VP62	5.3	6.3	-	6.3	6.1	5.9	5.7	5.5	5.3
	1VP65	2VP65	5.2	6.4	6.4	6.2	6.0	5.8	5.6	5.4	5.2
	1VP68	2VP68	5.9	6.9	-	6.9	6.7	6.5	6.3	6.1	5.9
	1VP71	2VP71	5.8	7.0	7.0	6.8	6.6	6.4	6.2	6.0	5.8
	1VP75	2VP75	6.2	7.4	7.4	7.2	7.0	6.8	6.6	6.4	6.2